

IBM Storage Solution Rack



2101 Model 200 Installation and Service Guide

IBM Storage Solution Rack



2101 Model 200 Installation and Service Guide

Note:

Before using this information and the product it supports, read the general information in “Safety and environmental notices” on page vii, and “Notices” on page 43.

Second Edition (March 2005)

© Copyright International Business Machines Corporation 2005. All rights reserved.

US Government Users Restricted Rights – Use, duplication or disclosure restricted by GSA ADP Schedule Contract with IBM Corp.

Contents

Figures	v
--------------------------	----------

Safety and environmental notices	vii
Safety inspection procedure	vii
Laser safety	ix
General restrictions	ix
Usage restrictions	ix
Environmental notices and statements	ix
Product recycling and disposal	ix
Battery return program	ix

About this book	xi
Who should use this book	xi
Getting information, help, and service	xi
Before you call	xi
Using the documentation	xi
Web sites	xii
Software service and support	xii
Hardware service and support	xii
Fire suppression systems	xiii
How to send your comments	xiii

Chapter 1. Installing the 2101 Model 200	1
Step 1. Positioning the rack	2
Step 2. Leveling the rack	3
Step 3. Attaching the stabilizers	3
Step 4. Attaching the rack to a concrete floor	4
Step 5. Attaching the rack to a concrete floor beneath a raised floor	6
Step 6. Attaching the mounting plates	9
Step 7. Attaching the front door	9
Step 8. Checking the customer's ac power source	10
Step 9. Connecting drawer and device cables	11
Step 10. Powering on the system	11

Chapter 2. 2101 Model 200 rack power distribution	13
Power distribution units (PDUs)	13
Type 6 PDU	13
9188/7188 PDU	16
External ac power cords	19
Testing the PDU	20
Safety notices	20
Testing procedure	20

Chapter 3. Servicing the 2101 Model 200 rack	23
---	-----------

Safety notices	23
Power-on procedure	23
Power-off procedure	24
Removing and replacing the PDU	24
Removing the PDU	24
Replacing the PDU	25
Removing and replacing the front or rear door	25
Removing the door	25
Replacing the door	26
Relocating a rack	26

Chapter 4. Parts information and product specifications	29
Covers	29
Earthquake brace	30
Blank fillers	31
Power distribution unit (PDU)	32
Stabilizers	33
Leveling feet	34
Power cords	34
2101 Model 200 rack specifications	36

Hardware warranty	39
Statement of limited warranty	39
Production status	39
IBM warranty for machines	39
Warranty service	40
Extent of warranty	40
Limitation of liability	41

Notices	43
Trademarks	43
Electronic emission statements	44
Federal Communications Commission (FCC) statement	44
Industry Canada compliance statement	44
European community compliance statement	44
Germany compliance statement	45
Japanese Voluntary Control Council for Interference (VCCI) class 1 statement	46
Korean Government Ministry of Communication (MOC) statement	46
Taiwan class A compliance statement	46

Glossary	47
---------------------------	-----------

Index	57
------------------------	-----------

Figures

1. Ground check	viii	11. Type 6 power distribution unit	14
2. Caster wheel	2	12. Type 6 PDU ac diagram	15
3. Leveling adjustments.	3	13. Type 6 PDU to drawer or rack frame grounding	16
4. Stabilizers	4	14. 9188/7188 power distribution unit	17
5. Attaching the rack to a concrete floor	4	15. 9188/7188 PDU ac diagram	18
6. Leveling the rack	6	16. 9188/7188 PDU to drawer or rack frame grounding	19
7. Attaching the rack to a raised floor	7	17. Removing the door	26
8. Leveling the rack	8		
9. Attaching the mounting plate	9		
10. Installing the front door	10		

Safety and environmental notices

Safety notices are printed throughout this book.

A *danger* notice indicates the presence of a hazard that has the potential of causing death or serious personal injury.

A *caution* notice indicates the presence of a hazard that has the potential of causing moderate or minor personal injury.

An *attention* notice indicates the possibility of damage to a program, device, system, or data.

Safety inspection procedure

Perform a safety inspection on the rack when any of the following conditions occur:

- The rack is inspected under a maintenance agreement.
- Service is requested and service has not recently been performed.
- An alterations-and-attachments review is performed.
- Changes have been made to the equipment that might affect the safe operation of the equipment.
- External devices with an attached power cord are connected to the rack.

Be cautious of potential safety hazards that are not covered in the safety checks. If the inspection indicates an unacceptable safety condition, the condition must be corrected before you can service the machine.

Note: It is the responsibility of the owner of the system to correct any unsafe condition.

Do the following safety checks:

1. If the rack is bolted down, ensure that the rack is firmly secured to the floor. See Figure 5 on page 4.
2. If the rack is not bolted down, ensure that the stabilizers are firmly attached to both the bottom front and bottom rear of the rack. See Figure 4 on page 4.

CAUTION:

The stabilizer must be firmly attached to the bottom front and bottom rear of the rack to prevent the rack from turning over when the drawers are pulled out of the rack. Do not pull out or install any drawer or feature if the stabilizer is not attached to the rack.

3. Check the covers for sharp edges and for damage or alterations that expose the internal parts of the rack.
4. Check the covers for a proper fit to the rack. The covers should be in place and secure.
5. Open the back door of the rack.
6. Perform the power-off procedure for the power distribution unit (PDU) that is installed in the rack. See “Power-off procedure” on page 24 for power-off procedures.

7. Check for alterations or attachments. If there are any, check for obvious safety hazards such as broken wires, sharp edges, or broken insulation.
8. Check the internal cables for damage.
9. Check for dirt, water, and any other contamination within the rack.
10. Check the voltage label on the back of the system unit to ensure that it matches the voltage at the outlet.
11. Check the external power cable for damage.
12. Perform the following grounding checks:
 - a. With the external power cord connected to the system unit, check for 0.1 ohm or less resistance between the ground plug on the external power cord plug and the metal frame. See Figure 1.

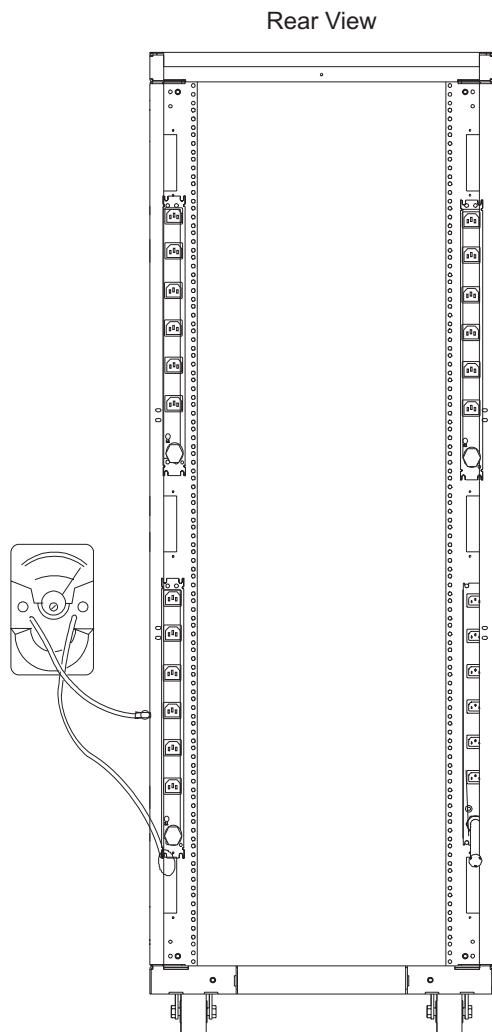

RT000015

Figure 1. Ground check

- b. Using the appropriate probe, check for 0.1 ohm or less resistance between the metal frame and the grounding pin on each of the power outlets on each power distribution bus.
13. Check for the following conditions for each external device that has an attached power cord:

- Damage to the power cord.
 - The correct grounded power cord.
 - With the external power cord connected to the device, check for 0.1 ohm or less resistance between the ground lug on the external power cord plug and the metal frame of the device.
14. Close the rear cover of the rack.
 15. Perform the power-on procedure for the PDU that is installed in the rack. See “Power-on procedure” on page 23 for power-on procedures.

Laser safety

This unit might contain a single-mode or a multi-mode transceiver class 1 laser product which complies with IEC 825-1 and FDA 21 CFR 1040.10 and 1040.11. The transceiver must be operated under the recommended operating conditions.

General restrictions

The classification of the laser is valid only if the module is operated within the specified temperature and voltage limits. The system using the module must provide power supply protection that guarantees that the system power source will cease to provide power if the maximum recommended operation limit or more is detected on the +3.3 V or the +5 V at the power source. The operating temperature of the module must be in the temperature range given in the recommended operating limits. These limits guarantee the laser safety.

Usage restrictions

The optical ports of the modules must be terminated with an optical connector or with a dust plug.

Environmental notices and statements

This section covers product recycling and product disposal.

Product recycling and disposal

This unit might contain materials such as circuit boards, cables, electromagnetic compatibility gaskets, and connectors which may contain lead and copper/beryllium alloys that require special handling and disposal at end of life. Before this unit is disposed of, these materials must be removed and recycled or discarded according to applicable regulations. IBM® offers product-return programs in several countries. Information on product recycling offerings can be found on IBM’s Internet site at

www.ibm.com/ibm/environment/products/prp.shtml

IBM encourages owners of information technology (IT) equipment to responsibly recycle their equipment when it is no longer needed. IBM offers a variety of programs and services to assist equipment owners in recycling their IT products. Information on product recycling offerings can be found on IBM’s Internet site at

www.ibm.com/ibm/environment/products/prp.shtml

Battery return program

This product may contain a sealed lead acid, nickel cadmium, nickel metal hydride, lithium, or lithium ion battery. Consult your user manual or service

manual for specific battery information. The battery must be recycled or disposed of properly. Recycling facilities may not be available in your area. For information on disposal of batteries outside the United States, see <http://www.ibm.com/ibm/environment/products/batteryrecycle.shtml> or contact your local waste disposal facility.

In the United States, IBM has established a return process for reuse, recycling, or proper disposal of used IBM sealed lead acid, nickel cadmium, nickel metal hydride, and battery packs from IBM equipment. For information on proper disposal of these batteries, contact IBM at 1-800-426-4333. Have the IBM part number listed on the battery available prior to your call.

In the Netherlands, the following applies.



For Taiwan: Please recycle batteries.



About this book

This book provides installation and maintenance information that is specific to the IBM 2101 Model 200 rack.

Who should use this book

This book is used by the service representative to install or repair the 2101 Model 200 rack.

Getting information, help, and service

If you need help, service, or technical assistance or just want more information about IBM products, you will find a wide variety of sources available from IBM to assist you. This section contains information about where to go for additional information about IBM and IBM products, what to do if you experience a problem with your IBM @server xSeries® or IntelliStation® system, and whom to call for service, if it is necessary.

Before you call

Before you call, make sure that you have taken these steps to try to solve the problem yourself:

- Check all cables to make sure that they are connected.
- Check the power switches to make sure that the system is turned on.
- Use the troubleshooting information in your system documentation and use the diagnostic tools that come with your system.
- Check for technical information, hints, tips, and new device drivers at the following Web site:
www.ibm.com/servers/storage/support/disk/
- Use an IBM discussion forum on the IBM Web site to ask questions.

You can solve many problems without outside assistance by following the troubleshooting procedures that IBM provides in the online help or in the documents that are provided with your system and software. The information that comes with your system also describes the diagnostic tests that you can perform. Most xSeries and IntelliStation systems, operating systems, and programs come with information that contains troubleshooting procedures and explanations of error messages and error codes. If you suspect a software problem, see the information for the operating system or program.

Using the documentation

Information about the xSeries or IntelliStation system and preinstalled software, if any, is available in the documents that come with your system. This includes printed documents, online documents, readme files, and help files. See the troubleshooting information in your system documentation for instructions on how to use the diagnostic programs. The troubleshooting information or the diagnostic programs might tell you that you need additional or updated device drivers or other software.

Web sites

IBM maintains pages on the World Wide Web where you can get the latest technical information and download device drivers and updates.

- For DS4000 and DS6000 information, go to the following Web site:

www.ibm.com/servers/storage/support/disk/

The support page has many sources of information and ways for you to solve problems, including:

- Diagnosing problems using the IBM Online Assistant
 - Downloading the latest device drivers and updates for your products
 - Viewing frequently asked questions (FAQ)
 - Viewing hints and tips to help you solve problems
 - Participating in IBM discussion forums
 - Setting up e-mail notification of technical updates about your products
- You can order publications through the IBM Publications Ordering System at the following web site:
www.elink.ibm.com/public/applications/publications/cgibin/pbi.cgi/
 - For the latest information about IBM xSeries products, services, and support, go to the following Web site:
www.ibm.com/eserver/xseries/
 - For the latest information about IBM pSeries® products, services, and support, go to the following Web site:
www.ibm.com/eserver/pseries/
 - For the latest information about the IBM IntelliStation information, go to the following Web site:
www-132.ibm.com/content/home/store_IBMPublicUSA/en_US/IntelliStation_workstations.html
 - For the latest information about operating system and HBA support, clustering support, SAN fabric support, and Storage Manager feature support, see the TotalStorage® DS4000 Interoperability Matrix at the following Web site:
www.ibm.com/servers/storage/disk/ds4000/interop-matrix.html

Software service and support

Through IBM Support Line, for a fee you can get telephone assistance with usage, configuration, and software problems with xSeries servers, IntelliStation workstations, and appliances. For information about which products are supported by Support Line in your country or region, go to the following Web site:

www.ibm.com/services/sl/products/

For more information about the IBM Support Line and other IBM services, go to the following Web sites:

- www.ibm.com/services/
- www.ibm.com/planetwide/

Hardware service and support

You can receive hardware service through IBM Integrated Technology Services or through your IBM reseller, if your reseller is authorized by IBM to provide warranty service. Go to the following Web site for support telephone numbers:

www.ibm.com/planetwide/

In the U.S. and Canada, hardware service and support is available 24 hours a day, 7 days a week. In the U.K., these services are available Monday through Friday, from 9 a.m. to 6 p.m.

Fire suppression systems

A fire suppression system is the responsibility of the customer. The customer's own insurance underwriter, local fire marshal, or a local building inspector, or both, should be consulted in selecting a fire suppression system that provides the correct level of coverage and protection. IBM designs and manufactures equipment to internal and external standards that require certain environments for reliable operation. Because IBM does not test any equipment for compatibility with fire suppression systems, IBM does not make compatibility claims of any kind nor does IBM provide recommendations on fire suppression systems.

How to send your comments

Your feedback is important in helping us to provide the most accurate and high-quality information. If you have comments or suggestions for improving this publication, you can send us comments electronically by using these addresses:

- Internet: starpubs@us.ibm.com
- IBMLink™ from U.S.A.: STARPUBS at SJEVM5
- IBMLink from Canada: STARPUBS at TORIBM
- IBM Mail Exchange: USIB3WD at IBMMAIL

You can also mail your comments by using the Reader Comment Form in the back of this manual or direct your mail to:

International Business Machines Corporation
Information Development
Dept. GZW
9000 South Rita Road
Tucson, AZ 85744-0001
U.S.A.

Chapter 1. Installing the 2101 Model 200

This chapter contains the procedures for installing a 2101 Model 200 rack and preparing it for operation. The 2101 Model 200 rack supports DS4000 and DS6000 series drawers.

The following safety notices apply to the procedures in this chapter. Review this section carefully before installing the 2101 Model 200 rack.

DANGER

An electrical outlet that is not correctly wired could place hazardous voltage on metal parts of the system or the devices that attach to the system. It is the responsibility of the customer to ensure that the outlet is correctly wired and grounded to prevent an electrical shock.

Before installing or removing signal cables, ensure that the power cables for the system unit and all attached devices are unplugged.

When adding or removing any additional devices to or from the system, ensure that the power cables for those devices are unplugged before the signal cables are connected. If possible, disconnect all power cables from the existing system before you add a device.

Use one hand, when possible, to connect or disconnect signal cables to prevent a possible shock from touching two surfaces with different electrical potentials.

During an electrical storm, do not connect cables for display stations, printers, telephones, or station protectors for communication lines.

CAUTION:

This product is equipped with a 3-wire power cable and grounded plug for the user's safety. Use this power cable in conjunction with a properly grounded electrical outlet to avoid electrical shock.

CAUTION:

This unit may have more than one power supply cord. To completely remove power, you must disconnect all power supply cords.

CAUTION:

Make sure that you do the following:

- Before you add or remove drawers, always have the leveling feet lowered and the front and rear stabilizer installed, or have the rack bolted to the floor.
- Always install drawers at the bottom of the rack first.
- Always remove drawers from the top of the rack first.
- Always install the heaviest drawers on the bottom of the rack.
- Remove two or three drawers from the top of the rack before you relocate it.
- Never push on the sides of the rack.

Attention: If the rack has equipment located above EIA location 32, you must remove the equipment in position 32 and above from the rack before you move it. Always remove the equipment from the *top* of the rack first.

Step 1. Positioning the rack

Read before installing the 2101 Model 200 rack:

The IBM 2101 Model 200 rack requires installation by IBM. Some pre-installed products might not require installation by IBM and could be customer set-up (CSU). Check to see if the rack contains pre-installed CSU products, such as the 2106. Ask the customer if they have purchased installation services from IBM for CSU products before installing anything more than the 2101 Model 200 rack itself.

Note: The customer should have unpacked the rack and positioned it in the room. If this has not been done, you will need to do so before installing the rack.

1. If the customer has not unpacked and positioned the rack, do the following:
 - a. Remove all packing and tape from the rack.
 - b. Position the rack according to the customer floor plan.
2. Lock each caster wheel by tightening the screw on the caster. See Figure 2.

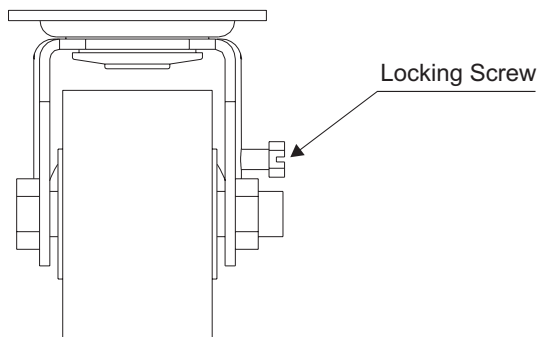

RT000001

Figure 2. Caster wheel

Use the following to determine the next step:

- If the rack is not being attached to the floor, go to the next step.
- If the rack is being bolted to a concrete floor, go to "Step 4. Attaching the rack to a concrete floor" on page 4.

- If the rack is being bolted to a concrete floor beneath a raised floor, go to “Step 5. Attaching the rack to a concrete floor beneath a raised floor” on page 6.

Step 2. Leveling the rack

Complete the following steps to adjust the leveling feet:

1. Loosen the jam nut on each leveling foot by turning the nut counterclockwise, away from the bottom of the rack. See Figure 3.
2. Rotate each leveling foot downward until it contacts the surface on which the rack is placed.
3. Adjust the leveling feet downward as needed until the rack is level. When the rack is level, tighten the jam nuts against the base by turning the nut clockwise, toward the bottom of the rack.

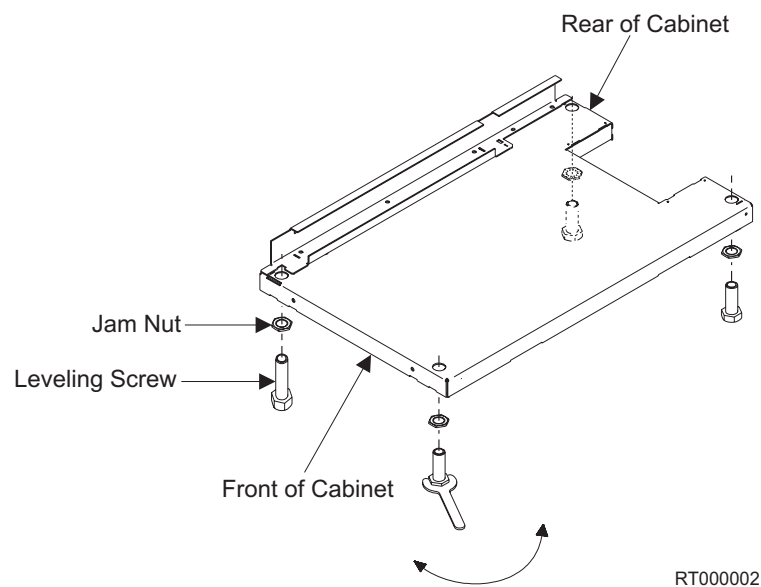

Figure 3. Leveling adjustments

Step 3. Attaching the stabilizers

CAUTION:

The stabilizers must be firmly attached to the bottom front and bottom rear of the rack to prevent the rack from turning over when the drawers are pulled out of the rack. Do not pull out or install any drawer or feature if the stabilizers are not attached to the rack.

1. Align the slots in the stabilizer with the mounting holes at the bottom front of the rack. See Figure 4 on page 4.
2. Install the two mounting screws.
3. Ensure that the base of the stabilizer rests firmly on the floor. Use the allen wrench that is supplied with the rack to alternately tighten the mounting screws until they are tight.

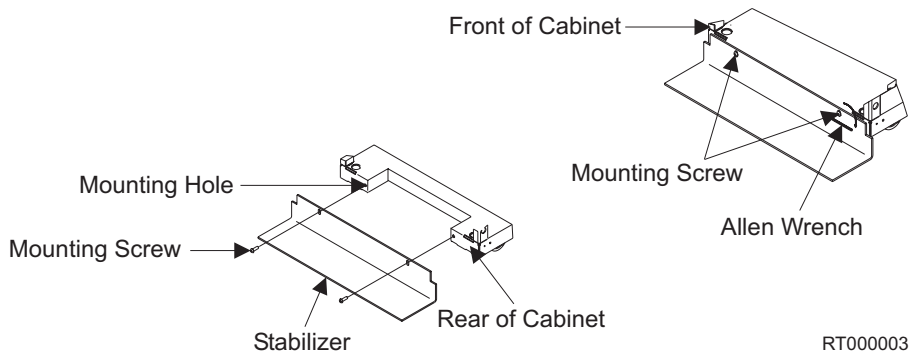

RT000003

Figure 4. Stabilizers

- Repeat steps 1 through 3 to install the stabilizer at the bottom rear of the rack.

Step 4. Attaching the rack to a concrete floor

This procedure covers attaching the rack-mounting plates directly to a concrete floor.

Refer to Figure 5 while completing these steps.

Note: The customer is responsible for attaching the rack-mounting plates to the concrete floor. The following steps guide the customer in aligning and installing the rack-mounting plates.

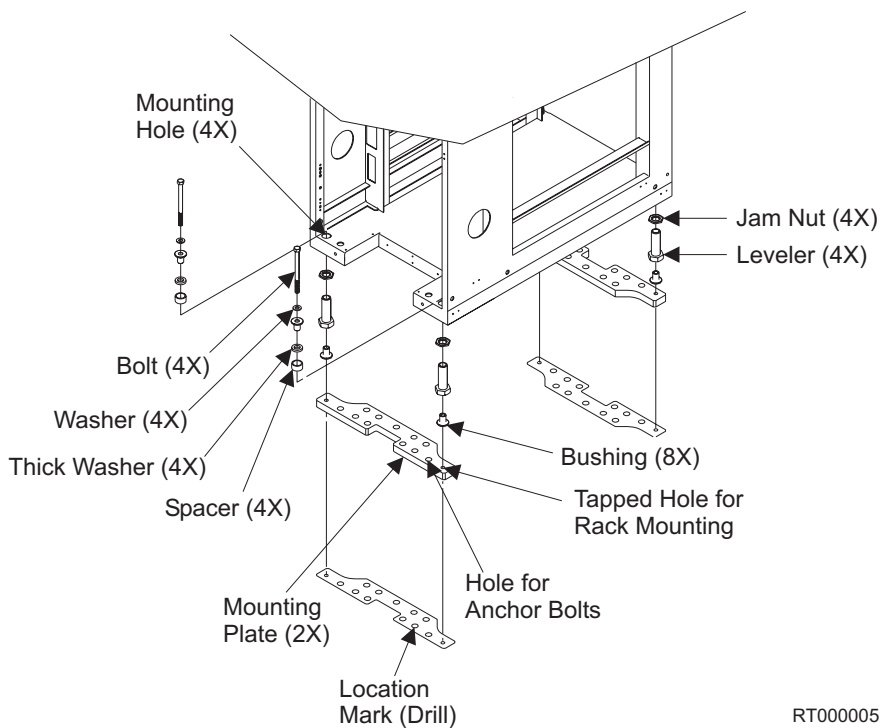

RT000005

Figure 5. Attaching the rack to a concrete floor

- Ensure that the rack is in the correct location.
- In this rack, the bushings are temporarily installed to help position the rack-mounting plates.

3. Ensure that the bushing is in the leveling foot. Position the two rack-mounting plates in the approximate mounting location under the rack. If necessary, raise the leveling feet for clearance.
4. Place a bushing on a rack-mounting bolt. Insert the bolt and bushing through the leveling foot and bushing and out the bottom bushing.
5. Insert the four rack-mounting bolts through the leveling feet and bushings, and out the bottom of the rack.
6. Position the rack-mounting plates under the four rack-mounting bolts so that the rack-mounting bolts are centered directly over the tapped holes.
7. Turn the rack-mounting bolts 3 - 4 turns into the tapped holes.
8. Mark the floor around the edges of both rack-mounting plates.
9. Mark the rack-mounting plate bolt-down holes that are accessible through the opening in the rear of the rack.
10. Remove the rack-mounting bolts and bushings.
11. Remove the rack-mounting plates.
12. Loosen the locking screws on the casters, and move the rack so that it is clear of the locator marks for the rack-mounting plates.
13. Position the rack-mounting plates within the marked areas.
14. Mark the floor at the center of each hole in the rack-mounting plates (including the tapped holes).
15. Remove the two rack-mounting plates from the marked locations.
16. At the marked location of the tapped rack-mounting bolt holes, drill four holes approximately 5 cm (2 in.) deep to allow clearance for the ends of the four rack-mounting bolts. The ends of the rack-mounting bolts protrude past the thickness of the mounting plate.

Note: You must use a minimum of two anchor bolts for each rack-mounting plate to attach it to the concrete floor. Because some of the holes in the rack-mounting plates might align with concrete reinforcement rods below the surface of the concrete, some of the rack-mounting plate holes might not be suitable.

17. For each rack-mounting plate, select at least two suitable holes. Select holes as close to the threaded holes as possible. Be sure that the holes you select at the rear of the rack are accessible. Drill the selected holes (two for each rack-mounting plate).
18. Position the front rack-mounting plate within the marked area.
19. Using anchor bolts, attach the front rack-mounting plate to the concrete floor.

Note: Do not use the four plastic isolator bushings.

20. Position the rack over the front rack-mounting plate.
21. Position the rear rack-mounting plate within the marked area.
22. Using anchor bolts, attach the rear rack-mounting plate to the concrete floor.
23. Insert each of the rack-mounting bolts through a flat washer, a thick washer, and through a leveling foot.
24. Align the four rack-mounting bolts with the four tapped holes in the two rack-mounting plates and turn the bolts 3 - 4 rotations.
25. Tighten the locking screw on each caster.
26. Adjust the leveling screw downward as needed until the rack is level. See Figure 6 on page 6. When the rack is level, tighten the jam nuts against the

base by turning the jam nut clockwise, toward the bottom of the rack. Torque the four bolts to 54 - 67 nm (40 - 50 ft-lbs).

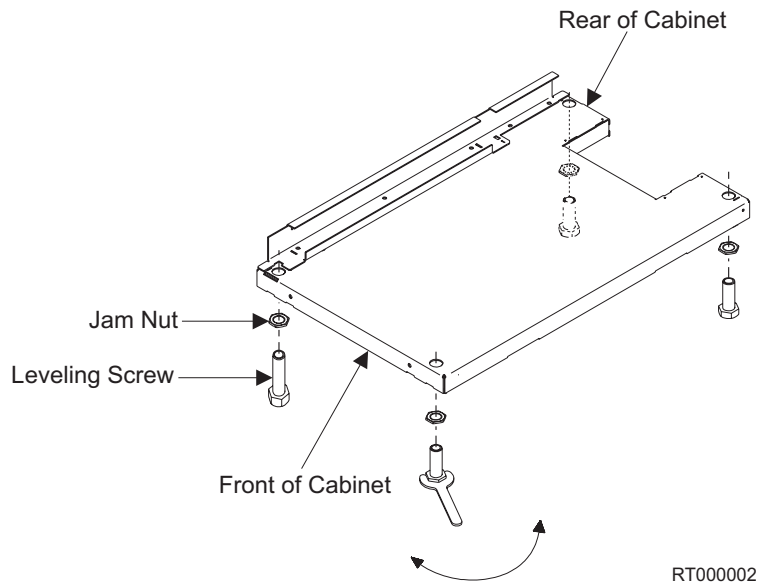

Figure 6. Leveling the rack

27. After all the racks are bolted down, go to “Step 6. Attaching the mounting plates” on page 9.

Step 5. Attaching the rack to a concrete floor beneath a raised floor

Refer to Figure 7 on page 7 while completing these steps.

This procedure covers attaching the rack-mounting plates to the concrete floor beneath a raised floor.

Note: The customer is responsible for attaching the rack-mounting plates to the concrete floor. The following steps guide the customer in aligning and installing the rack-mounting plates.

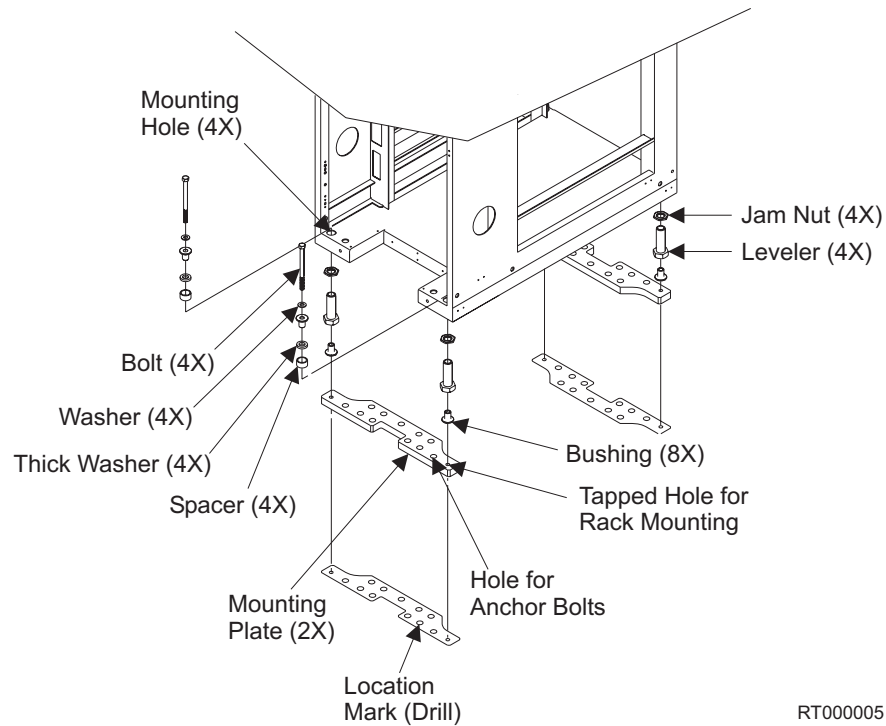

RT000005

Figure 7. Attaching the rack to a raised floor

1. Ensure that the rack is in the correct location.
2. In this rack, the bushings are temporarily installed to help position the rack-mounting plates.
3. Ensure that the bushing is in the leveling foot. Position the two rack-mounting plates in the approximate mounting locations under the rack. If necessary, raise the leveling feet for clearance.
4. Place a bushing on a rack-mounting bolt. Insert the bolt and bushing through the leveling foot and bushing and out the bottom bushing.
5. Insert the four rack-mounting bolts through the leveling feet and bushings, and out the bottom of the rack.
6. Position the rack-mounting plates under the four rack-mounting bolts so that the rack-mounting bolts are centered directly over the tapped holes.
7. Turn the rack-mounting bolts 3 - 4 turns into the tapped holes.
8. Mark the raised-floor panel around the edges of both rack-mounting plates.
9. Mark the rack-mounting plate bolt-down holes that are accessible through the opening in the rear of the rack.
10. Remove the rack-mounting bolts and bushings.
11. Remove the rack-mounting plates.
12. Loosen the locking screws on the casters and move the rack so that it is clear of the locator marks for the rack-mounting plates.
13. Position the rack-mounting plates within the marked areas.
14. Mark the raised-floor panel at the center of each hole in the rack-mounting plates (including the tapped holes).
15. Remove the two rack-mounting plates from the marked locations.
16. Transfer the locations of the holes from the raised-floor panel to the concrete floor directly beneath, and mark the holes there.

Note: You must use a minimum of two anchor bolts for each rack-mounting plate to attach it to the concrete floor. Because some of the holes in the rack-mounting plates might align with concrete reinforcement rods below the surface of the concrete, some of the rack-mounting plate holes might not be suitable.

17. For each rack-mounting plate, select at least two suitable holes. Select holes as close to the threaded holes as possible. Be sure that the holes you select at the rear of the rack are accessible. Drill the selected holes (two for each rack-mounting plate) in the concrete floor.
18. Drill pass-through holes in the raised-floor panel at the location of the four rack-mounting bolts.
19. Position the front rack-mounting plate within the marked area.
20. Using anchor bolts, attach the front rack-mounting plate to the concrete floor. Do not use the four plastic isolator bushings.
21. Position the rack on the raised-floor panel over the front rack-mounting plate.
22. Position the rear rack-mounting plate within the marked area.
23. Using anchor bolts, attach the rear rack-mounting plate to the concrete floor.
24. Insert each of the rack-mounting bolts through a flat washer, a plastic isolator bushing, a thick washer, and through a leveling foot.
25. Align the four rack-mounting bolts with the four tapped holes in the two mounting plates and turn the bolts 3 - 4 rotations.
26. Tighten the locking screw on each caster.
27. Adjust the leveling feet downward as needed until the rack is level. See Figure 8. When the rack is level, tighten the jam nuts against the base by turning the jam nut clockwise (toward the bottom of the rack). Torque the four bolts to 54 - 67 nm (40 - 50 ft-lbs).

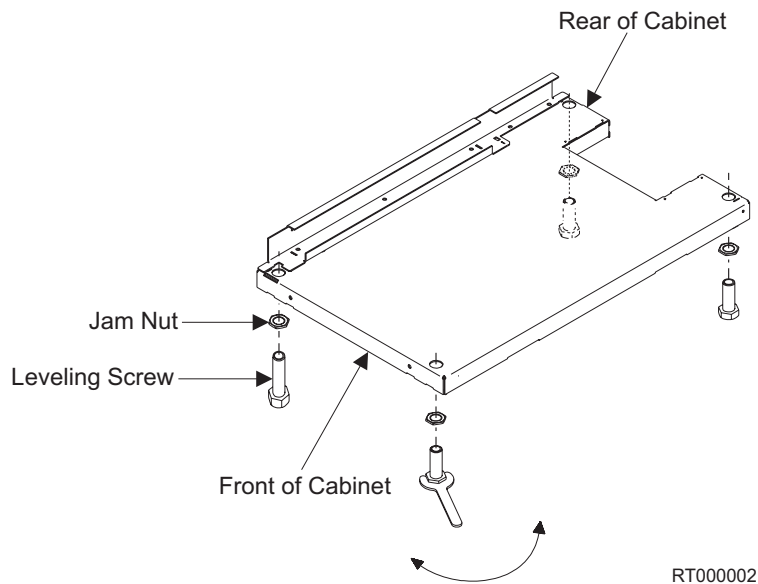

Figure 8. Leveling the rack

28. If the rack does not have a front door, install the top, left, and right trim panels.

29. After all the racks are bolted down, go to “Step 7. Attaching the front door.”

Step 6. Attaching the mounting plates

Note: You attach the front and rear mounting plates through the same mounting holes that are used to mount the stabilizers. Therefore, the rack must be bolted down rather than using the stabilizers. Install the mounting plates *only* if the rack is bolted to the floor.

The mounting plates are part of the Earthquake Mounting Kit, feature code 6080.

Using the allen wrench that is supplied with the rack, align the holes on the mounting plate with the holes on the front of the rack, and install the mounting plate screws (stabilizer mounting screws). Repeat this procedure for the mounting plate on the rear of the rack. See Figure 9.

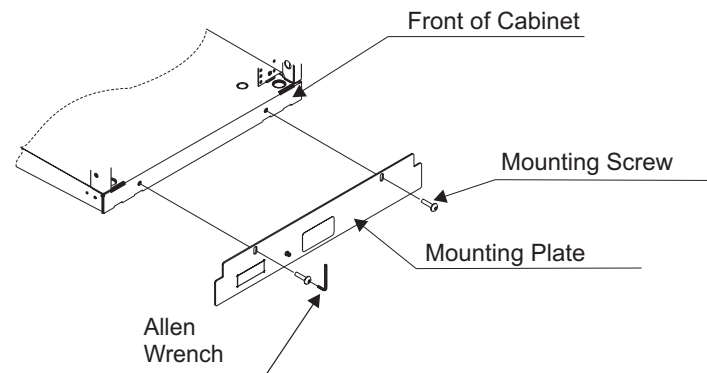

RT000008

Figure 9. Attaching the mounting plate

Step 7. Attaching the front door

If necessary, complete the following steps to install the front door:

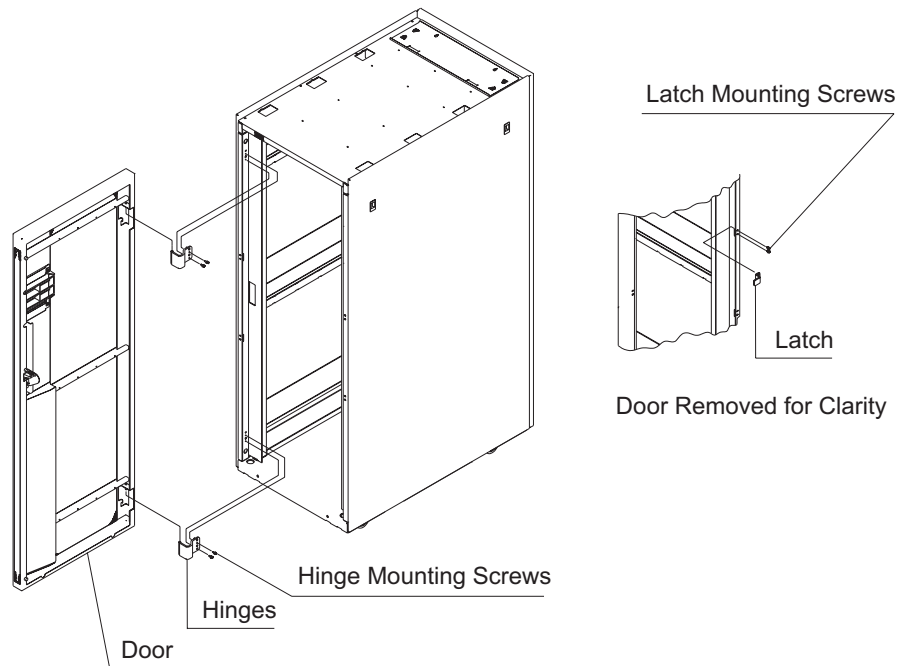

RT000022

Figure 10. Installing the front door

1. Install the hinges as shown in Figure 10.
2. Install the latch as shown in Figure 10.
3. Align the lower hinge pin on the front door with the hinge and partially insert the pin into the hinge.
4. Align the upper hinge pin with the hinge and lower the door into position.
5. Adjust the latch so that the door is latched securely.

Step 8. Checking the customer's ac power source

Before plugging the rack into the ac power source, do the following checks on the customer's ac power source.

CAUTION:

Do not touch the receptacle or the receptacle face plate with anything other than your test probes before you have met the requirements in this step.

1. Have the customer turn off the branch circuit breaker for the ac power outlet that the rack will plug into. Attach a "Do Not Operate" tag (S229-0237) to the circuit breaker switch.

Note: All measurements are made with the receptacle face plate in the normal installed position.

2. Some receptacles are enclosed in metal housings. For this type of receptacle, do the following:
 - a. Check for less than 1 volt from the receptacle case to any grounded metal structure in the building, such as a raised-floor metal structure, water pipe, building steel, or similar structure.
 - b. Check for less than 1 volt from the receptacle ground pin to a grounded point in the building.

Note: If the receptacle case or face plate is painted, be sure that the probe tip penetrates the paint and makes good electrical contact with the metal.

- c. Check the resistance from the ground pin of the receptacle to the receptacle case. Check the resistance from the ground pin to the building ground. The readings should be less than 1.0 ohm, which indicates the presence of a continuous grounding conductor.
3. If any of the three checks that you made in step 2 on page 10 are not correct, ask the customer to remove the power from the branch circuit and make the wiring corrections; then check the receptacle again.

Note: Do not use a digital multimeter to measure grounding resistance in the following steps.

4. Check for infinite resistance between the ground pin of the receptacle and each of the phase pins. This is a check for a wiring short to ground or a wiring reversal.
5. Check for infinite resistance between the phase pins. This is a check for a wiring short.

CAUTION:

If the reading is other than infinity, do not proceed! Have the customer make the necessary wiring corrections before continuing. Do not turn on the branch circuit breaker until all the above steps are satisfactorily completed.

6. Have the customer turn on the branch circuit breaker. Measure for the appropriate voltages between phases. If no voltage is present on the receptacle case or the ground pin, the receptacle is safe to touch.
7. With an appropriate meter, verify that the voltage at the ac outlet is correct.
8. Verify that the grounding impedance is correct by using the ECOS 1020, 1023, B7106, C7106, or an appropriately approved ground impedance tester.

Step 9. Connecting drawer and device cables

Most racks are configured in the factory, with all drawer and device cables installed.

If you need to install drawer and device cables, follow the installation instructions provided with the component being installed. The 2101 Model 200 rack supports DS4000 and DS6000 drawers and devices.

Attention: The power limitations of the PDU single-phase power cords limit the number of drawers that can be plugged into a pair of PDUs. **A maximum of six drawers can be plugged into a single pair of power distribution units (PDUs).** If you are installing and powering more than six drawers in a single rack, you must install a second pair of PDUs (making a total of four PDUs) to support the additional drawers. For more information, see Chapter 2, “2101 Model 200 rack power distribution,” on page 13.

Step 10. Powering on the system

Follow the power-on procedure in “Power-on procedure” on page 23 for your type of rack.

Chapter 2. 2101 Model 200 rack power distribution

This chapter contains information about the 2101 Model 200 rack, the Type 6 and 9188/7188 ac power distribution units (PDUs), and the procedure to test the PDUs. The 2101 Model 200 rack supports DS4000 and DS6000 drawers and devices.

Power distribution units (PDUs)

Power is distributed to the devices and drawers in the rack by power distribution units (PDUs). PDUs must be installed in pairs. A rack is configured with either two or four PDUs.

The 2101 Model 200 rack supports Type 6 PDUs and 9188/7188 PDUs.

- Type 6 PDUs have six IEC30–C13, 200 V to 240 V ac outlets. An additional two front outlets have limited access, as shown in Figure 11 on page 14. The input ac power to the PDU is not switched, so each outlet has a separate circuit breaker to protect against excessive current. See Figure 12 on page 15. The type 6 PDU feature codes are 6271 and 9271.
- 9188/7188 PDUs have twelve IEC30–C13, 200 V to 240 V ac outlets. See Figure 14 on page 17. The input ac power to the PDU is not switched, so each outlet has a separate circuit breaker to protect against excessive current. See Figure 15 on page 18.

You can mix Type 6 PDUs and 9188/7188 PDUs within a single rack.

The Type 6 PDU and 9188/7188 PDU are described in the following sections.

Type 6 PDU

Each type 6 PDU contains eight 200 V - 240 V ac outlets that provide power to the devices and drawers. See Figure 11 on page 14.

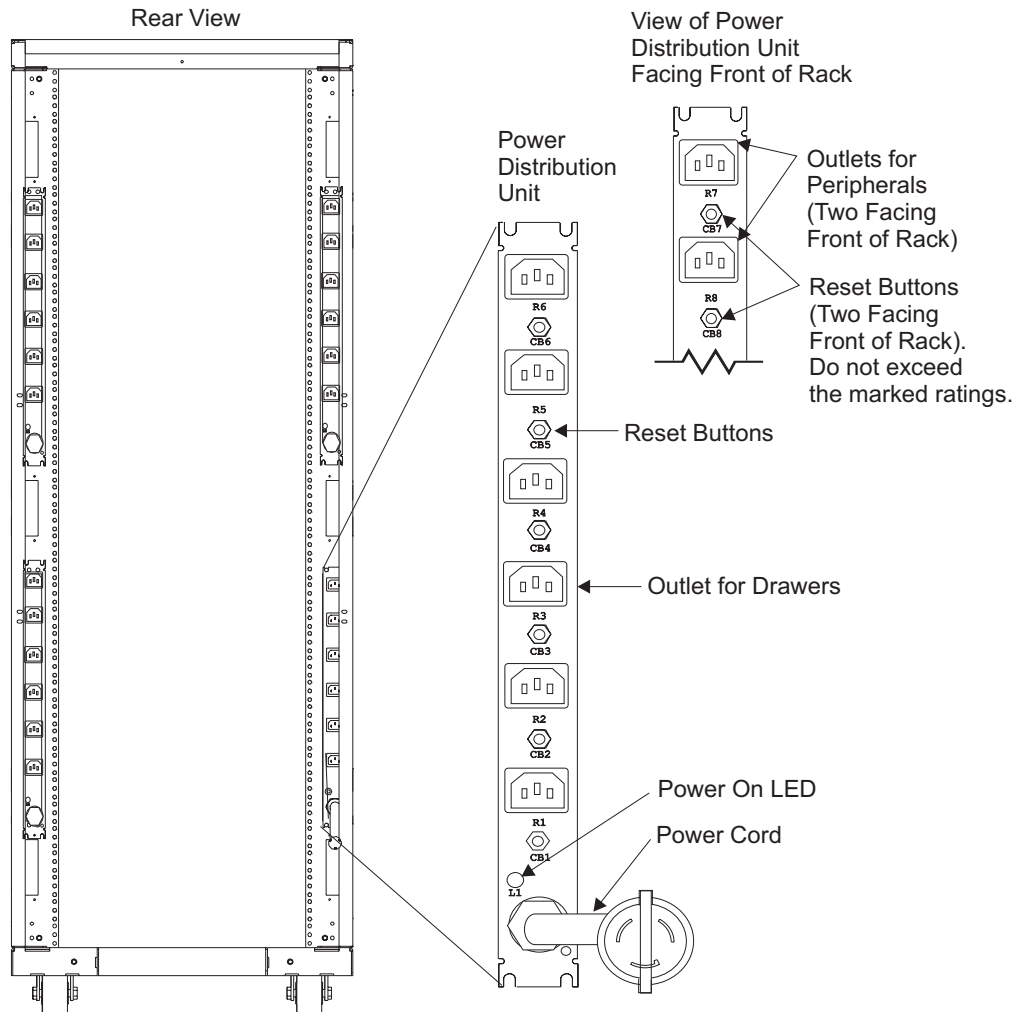

RT000012

Figure 11. Type 6 power distribution unit

Note: Only the six outlets on the front of the Type 6 PDU have current ratings that are suitable for product drawers. The two outlets facing the back of the Type 6 PDU are suitable for peripherals only. Do *not* plug DS4000 or DS6000 drawers into the two outlets on the back of the Type 6 PDU. Do not exceed the marked ratings at any time.

Attention: The power limitations of the PDU single-phase power cord limit the number of drawers that can be plugged into a pair of PDUs. **A maximum of six drawers can be plugged into a single pair of PDUs.** If you are installing and powering more than six drawers in a single rack, you must install a second pair of PDUs (making a total of four PDUs) to support the additional drawers.

The input ac power to the bus is not switched, so each outlet has a separate circuit breaker to protect against excessive current. See Figure 12 on page 15.

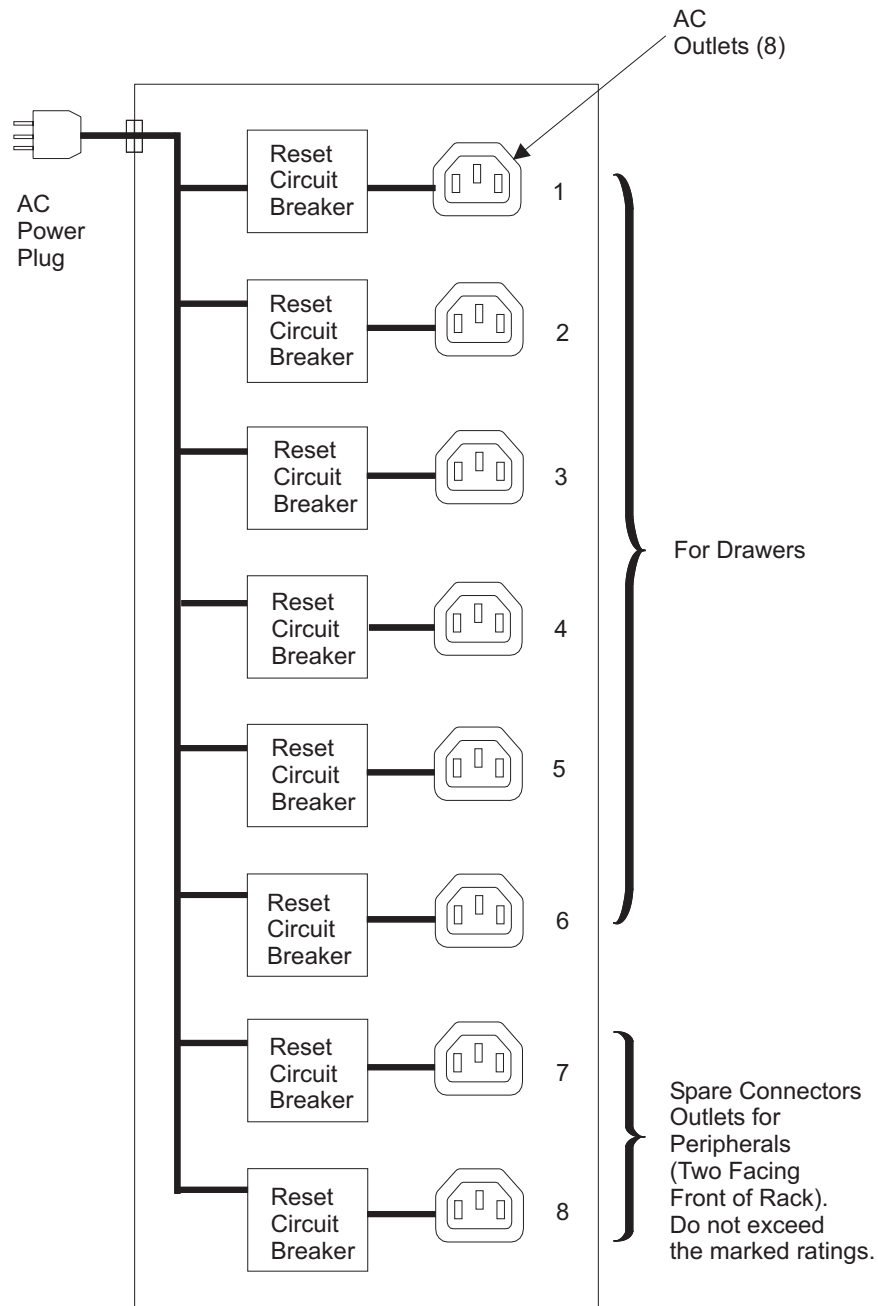

RT000013

Figure 12. Type 6 PDU ac diagram

When the drawer power cords are plugged into the outlets, there should be less than 1 ohm resistance between the drawer frames or the rack frame. See Figure 13 on page 16.

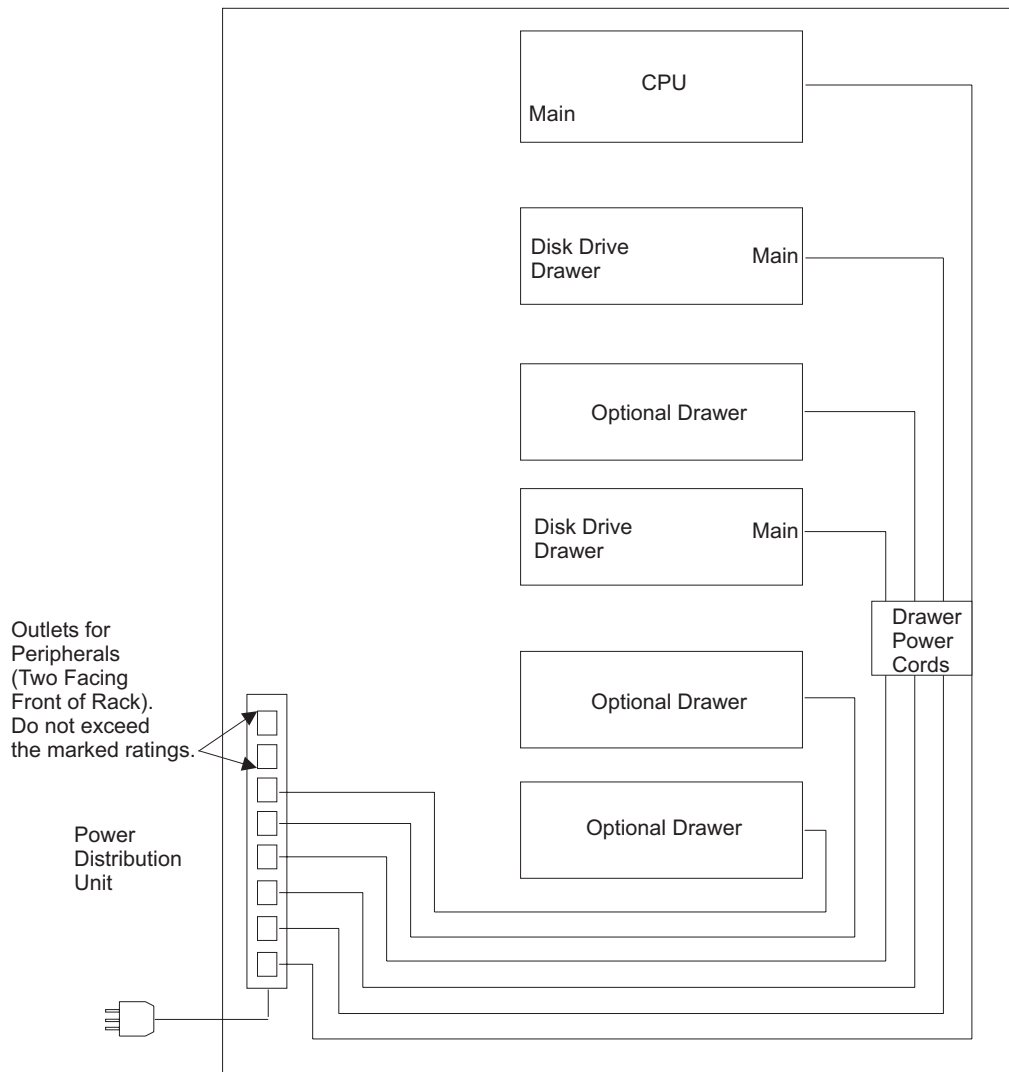

RT000014

Figure 13. Type 6 PDU to drawer or rack frame grounding

9188/7188 PDU

Each 9188/7188 PDU contains 12 200 V - 240 V ac outlets that provide power to the devices and drawers. See Figure 14 on page 17.

Attention: The power limitations of the PDU single-phase power cord limit the number of drawers that can be plugged into a pair of PDUs. **A maximum of six drawers can be plugged into a single pair of PDUs.** If you are installing and powering more than six drawers in a single rack, you must install a second pair of PDUs (making a total of four PDUs) to support the additional drawers.

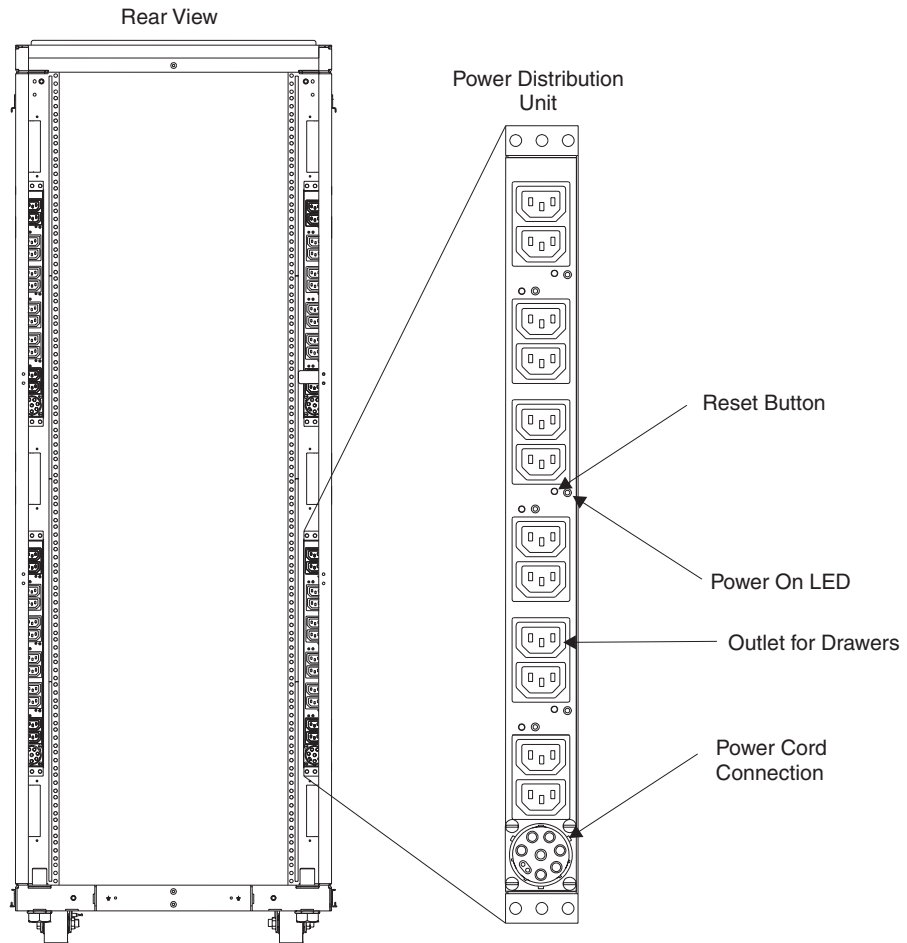
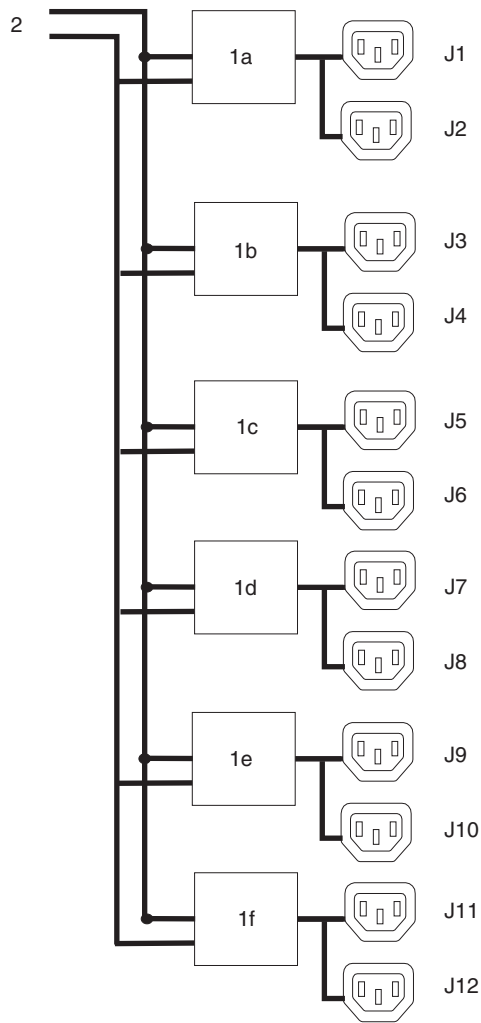

Figure 14. 9188/7188 power distribution unit

The input ac power to the bus is not switched, so each outlet has a separate circuit breaker to protect against excessive current. See Figure 15 on page 18.



- 1a** Circuit breaker 1 (20 Amp)
- 1b** Circuit breaker 1 (20 Amp)
- 1c** Circuit breaker 1 (20 Amp)
- 1d** Circuit breaker 1 (20 Amp)
- 1e** Circuit breaker 1 (20 Amp)
- 1f** Circuit breaker 1 (20 Amp)
- 2** AC Power Input
- J1-J12** AC Outlets

Figure 15. 9188/7188 PDU ac diagram

When the drawer power cords are plugged into the outlets, there should be less than 1 ohm resistance between the drawer frames or the rack frame. See Figure 16 on page 19.

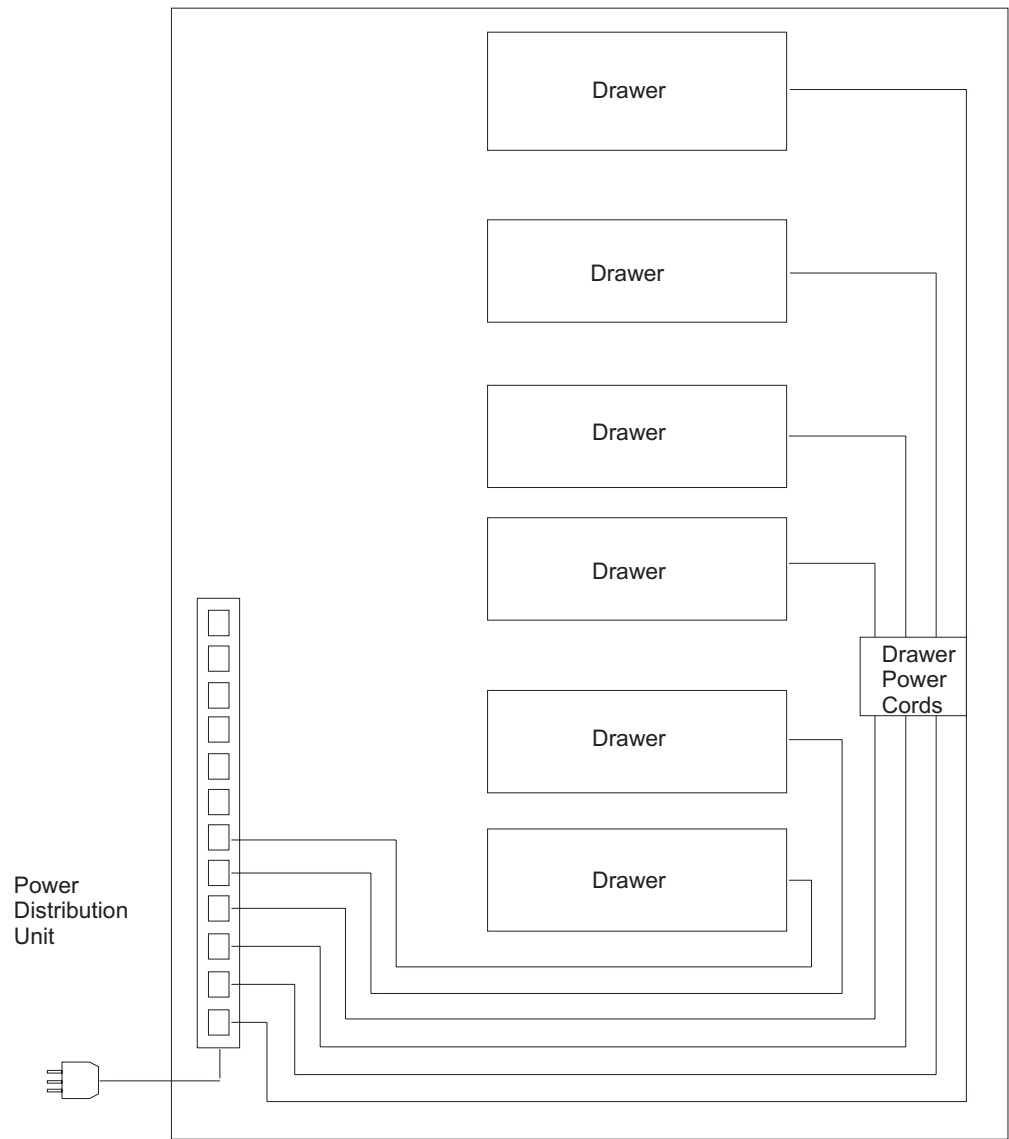

Rt000014b

Figure 16. 9188/7188 PDU to drawer or rack frame grounding

External ac power cords

To avoid electrical shock, the manufacturer provides a power cord with a grounded attachment plug. Use only properly grounded outlets.

Power cords that are used in the United States and Canada are listed by Underwriter's Laboratories (UL) and are certified by the Canadian Standards Association (CSA). These power cords consist of the following:

- Electrical cables, type ST
- Attachment plugs that comply with National Electrical Manufacturers Association (NEMA) L6-30P
- Appliance couplers that comply with International Electrotechnical Commission (IEC) Standard 320, Sheets C13 and C14.

Power cords that are used in other countries or regions consist of the following:

- Electrical cables, type HD21 or HD22
- Attachment plugs that are approved by the appropriate testing organization for the specific countries or regions where they are used
- Appliance couplers that comply with International Electrotechnical Commission (IEC) Standard 320, Sheet C13 and C14.

See “Power cords” on page 34 to find the power cords that are available for the rack.

Testing the PDU

Use this procedure to test the PDU. If you cannot determine which PDU is connected to the failing drawer, test the first PDU, and then test the other PDUs until the problem is isolated.

Safety notices

Observe the following safety notices during the testing procedures.

DANGER

An electrical outlet that is not correctly wired could place hazardous voltage on metal parts of the system or the devices that attach to the system. It is the responsibility of the customer to ensure that the outlet is correctly wired and grounded to prevent an electrical shock.

Before installing or removing signal cables, ensure that the power cables for the system unit and all attached devices are unplugged.

When adding or removing any additional devices to or from the system, ensure that the power cables for those devices are unplugged before the signal cables are connected. If possible, disconnect all power cables from the existing system before you add a device.

Use one hand, when possible, to connect or disconnect signal cables to prevent a possible shock from touching two surfaces with different electrical potentials.

During an electrical storm, do not connect cables for display stations, printers, telephones, or station protectors for communication lines.

CAUTION:

This unit may have more than one power cable. To completely remove power, you must disconnect all power cables from the unit.

Testing procedure

Perform the following procedure to test the PDU and to isolate any problems. Refer to Figure 11 on page 14 for the Type 6 PDU or Figure 14 on page 17 for the 9188/7188 PDU while completing these steps.

1. **Did the power on LED for any device come on and stay on?**
 - **Yes.** If a single device is not receiving power, go to step 3 on page 21.
 - **No.** If the power on LED is off, check the power cord for the proper voltage from the wall outlet to the PDU bus. Go to step 2 on page 21.

2. **Was the voltage correct?**
 - **Yes.** Go to step 7.
 - **No.** Check the customer's outlet for the correct voltage. If correct, exchange the power cable and then go to step 7.
3. **Did the drawer power reset circuit breaker on the PDU go to the Off position (pop out)?**
 - **Yes.** Go to step 6.
 - **No.** Go to step 4.
4. Do the following:
 - a. Plug the drawer power cable into another outlet on the PDU.
 - b. Turn on power to the drawer

Did the drawer power on LED come on and stay on?

 - **Yes.** The first outlet is defective. Use the second outlet or exchange the PDU. Go to step 7.
 - **No.** Go to step 5.
5. Do the following:
 - a. Plug the drawer power cable of another device or drawer into the same outlet.
 - b. Turn on power to the device or drawer.

The green light near the ac plug on the rear of some drawers indicates only that power is reaching the drawer and not that the power supply is operating.

Did the drawer power on LED come on and stay on, or are the fans operating?

 - **Yes.** The problem is probably located in the original drawer. Go to the power troubleshooting procedure for the drawer or device that is installed in the rack.
 - **No.** Exchange the PDU. Go to step 7.
6. Do the following:
 - a. Plug the drawer power cable into another outlet on the PDU.
 - b. Set the power button to on (button pushed in).

Did the circuit breaker go to the Off position (pop out)?

 - **Yes.** The drawer is overloading the circuit breaker. Ensure that the power rating on the circuit breaker is within the rating of the outlet. If possible, use an outlet on the PDU that is within the rating of the drawer. If the outlet rating is correct for the drawer, exchange the drawer power cable or power supply as directed by the power troubleshooting procedures for the drawer.
 - **No.** The first circuit breaker is probably defective. Use the second outlet, or exchange the PDU. Go to step 7.
7. Connect all drawer power cables to their original power outlets on the PDU.

Chapter 3. Servicing the 2101 Model 200 rack

This chapter contains information about powering the rack on and off, and removing and replacing components.

Safety notices

The following safety notices apply to all the procedures in this chapter. Review this section carefully before performing any power-related operations.

DANGER

An electrical outlet that is not correctly wired could place hazardous voltage on metal parts of the system or the devices that attach to the system. It is the responsibility of the customer to ensure that the outlet is correctly wired and grounded to prevent an electrical shock.

Before installing or removing signal cables, ensure that the power cables for the system unit and all attached devices are unplugged.

When adding or removing any additional devices to or from the system, ensure that the power cables for those devices are unplugged before the signal cables are connected. If possible, disconnect all power cables from the existing system before you add a device.

Use one hand, when possible, to connect or disconnect signal cables to prevent a possible shock from touching two surfaces with different electrical potentials.

During an electrical storm, do not connect cables for display stations, printers, telephones, or station protectors for communication lines.

CAUTION:

This unit may have more than one power cable. To completely remove power, you must disconnect all power cables from the unit.

Power-on procedure

This procedure covers powering on the rack. Refer to Figure 11 on page 14 for the Type 6 PDU or Figure 14 on page 17 for the 9188/7188 PDU while completing these steps.

1. Plug all drawer power cords into the outlets on the PDUs.
2. Plug the power cord of each PDU into the customer's ac power outlets.

CAUTION:

This product is equipped with a 3-wire power cable and plug for the user's safety. Use this power cable in conjunction with a properly grounded electrical outlet to avoid electrical shock.

3. Follow the power-on procedures for the drawers that are installed in the rack. For more information, refer to the documentation that is provided with the drawers.
4. Close the back door of the rack.

Power-off procedure

This procedure covers powering off a PDU.

1. Determine which drawers must be powered off to service the PDU. Open the rear door of the rack.

Check the power cabling from the drawers that are attached to the PDU that you are servicing. If these drawers have dual power cords and are plugged into PDUs with independent ac sources, these drawers might not need to be powered off.

Note: Because many drawers or devices can be connected to the system unit, it might be impractical for you to switch off power to all the drawers or devices and to unplug their power cables.

2. Removing power to drawers that are mounted in the rack can have an adverse affect to the customer's systems and networks if they are not properly prepared. Ensure that the customer is aware of any components or drawers in this rack that are about to be powered off.

Systems that are mounted in the rack should be properly shut down and powered off according to their documentation. Powering off network components such as hubs or switches might affect other network communications. Inform the customer before powering them off.

Before powering off DASD drawers or DASD controllers make sure the customer has removed, dismounted, or taken them off-line from their systems.

In some DASD controllers, such as the 2106-200, the cache batteries continue to drain after power off if not shut down properly. If, for example, you are shutting down a 2106-200 controller for longer than one day, complete the additional steps in the section about shutting down the subsystem in the *HSG80 Array Controller ACS Maintenance and Service Guide*. This prevents the ECB from discharging during planned power outages.

3. Turn off power to all drawers or devices that are connected to the PDUs that you are servicing.
4. Unplug all the drawer or device power cables from the PDUs that you are servicing.
5. Unplug the power cord from the customer's ac power outlet.

Removing and replacing the PDU

This section covers the removal and replacement procedures for both the Type 6 and 9188/7188 PDUs.

Removing the PDU

Complete the following steps to remove the PDU from the rack:

1. Follow the steps in "Power-off procedure."
2. Turn off power and disconnect the ac power distribution bus from the customer's ac power outlet. Record the locations of the drawer ac power cables that are plugged into the PDUs.
3. Unplug the drawer ac power cables from the PDUs.
4. Remove the four mounting screws from the PDU and pull the unit toward you to access the power connectors on the other side of the unit. Unplug the power cables from the other side of the unit.

Attention: If you are replacing a PDU with a 9188/7188 PDU, keep the four mounting screws for reuse. In addition, you must also remove the two L-shaped brackets and four bracket screws from the PDU and keep this bracket-mounting hardware for reuse. For more details, see “Power distribution unit (PDU)” on page 32.

5. Remove the PDU from the rack.

Replacing the PDU

Complete the following steps to replace a PDU in the rack:

1. Reconnect any power cables that you disconnected from the front side of the PDU.

Note: If you are replacing a failed PDU with a 9188/7188 PDU, attach the two L-shaped brackets and four bracket screws from the failed PDU to the replacement PDU. For more details, see “Power distribution unit (PDU)” on page 32.

2. Slide the PDU into position. Secure the PDU by installing the four mounting screws.

Note: If you are replacing a failed PDU with a 9188/7188 PDU, you must reuse the four mounting screws you saved from the failed PDU. For more details, see “Power distribution unit (PDU)” on page 32.

3. Reconnect any power cables that you disconnected from the PDU.
4. Plug the power cables into the locations that you recorded during the removal procedure.
5. Follow the steps in “Power-on procedure” on page 23.

Removing and replacing the front or rear door

During inspection or service procedures for certain drawers you might need to remove the front or rear door for better access.

Removing the door

Complete the following steps to remove the front or rear door:

1. Open the door of the rack.
2. Remove the door by lifting it up and out.
3. Remove the hinge bracket (if necessary) by removing the hinge mounting screws that attach the bracket to the rack. See Figure 17 on page 26.

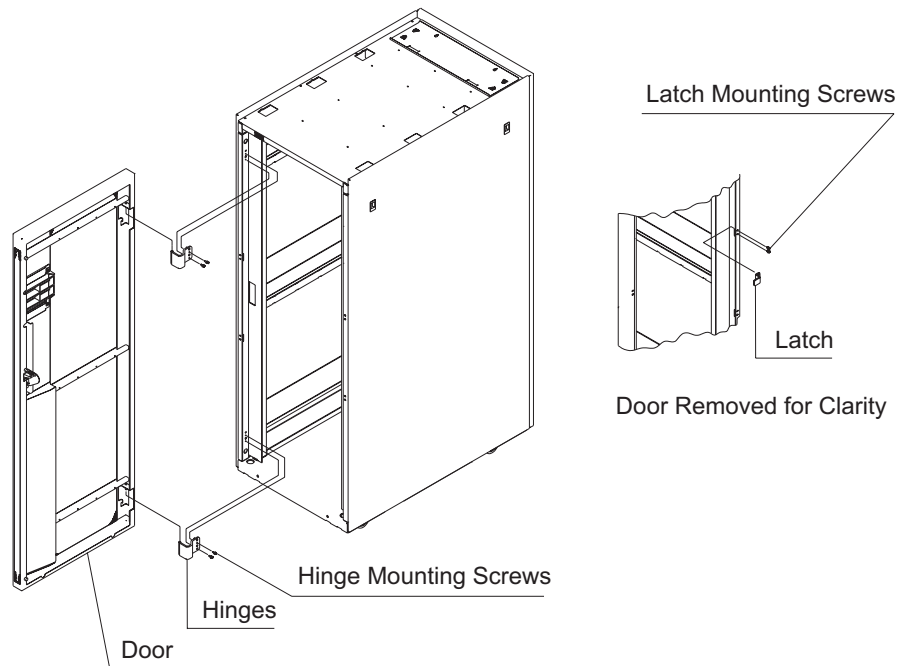

RT000022

Figure 17. Removing the door

Replacing the door

Complete the following steps to replace the front or rear door:

1. Install the bottom hinge pin (the longest pin) first.
2. Install the top hinge pin (the shortest pin) second.
3. Replace the door by performing the removal steps in the reverse order, ensuring that the hinge bracket mounting screws are securely fastened.

Relocating a rack

The following safety notices apply to the procedures in this section.

CAUTION:

Make sure that you do the following:

- Before you add or remove drawers, always have the leveling feet lowered and the front and rear stabilizer installed, or have the rack bolted to the floor.
- Always install drawers at the bottom of the rack first.
- Always remove drawers from the top of the rack first.
- Always install the heaviest drawers on the bottom of the rack.
- Remove two or three drawers from the top of the rack before you relocate it.
- Never push on the sides of the rack.

Attention: If the rack has equipment located above EIA location 32, you must remove the equipment in position 32 and above from the rack before you move it. Always remove the equipment from the *top* of the rack first.

Complete the following steps before you relocate a rack:

1. Turn off all power to the rack and the system that is installed.

2. Disconnect all power cables.
3. Make sure that the rack is either bolted down or has the stabilizers installed before continuing this procedure.
4. Before removing any drawers from the rack, ensure that the battery LEDs on the controller units are NOT blinking. A blinking LED indicates that the batteries are in use. To ensure that the batteries do not discharge during the relocation process, remove and reseal the battery packs before removing the drawer.

Complete the following steps to relocate the rack:

1. Unbolt the rack from the floor or remove the stabilizers.
2. Raise all the leveling feet.
3. Unlock each caster wheel by loosening the screw on the caster.
4. Move the rack to the new position.
5. Reposition the rack. Go to "Step 1. Positioning the rack" on page 2.

Chapter 4. Parts information and product specifications

This chapter contains detailed drawings, field replaceable unit (FRU) part numbers, part descriptions and product specification for a 2101 Model 200 rack.

Covers

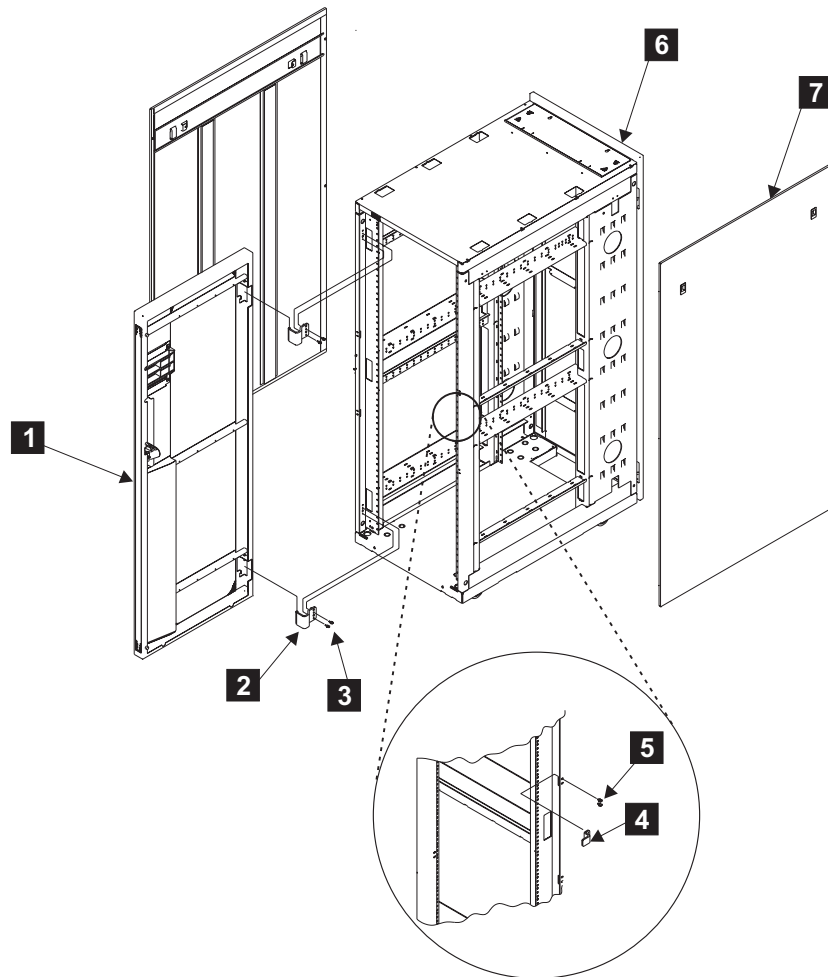

RT000017

Index number	FRU part number	Units per assembly	Description
1	18P2120	1	Front Door
2	31L7547	2	Hinge, front door
3	31L8594	4	Screw, front hinge
4	31L7545	1	Latch, front door
5	31L7540	2	Screw, front door latch
6	11P0724	1	Rear door (Black)
7	05N6478	2	Side panel (Black)

Earthquake brace

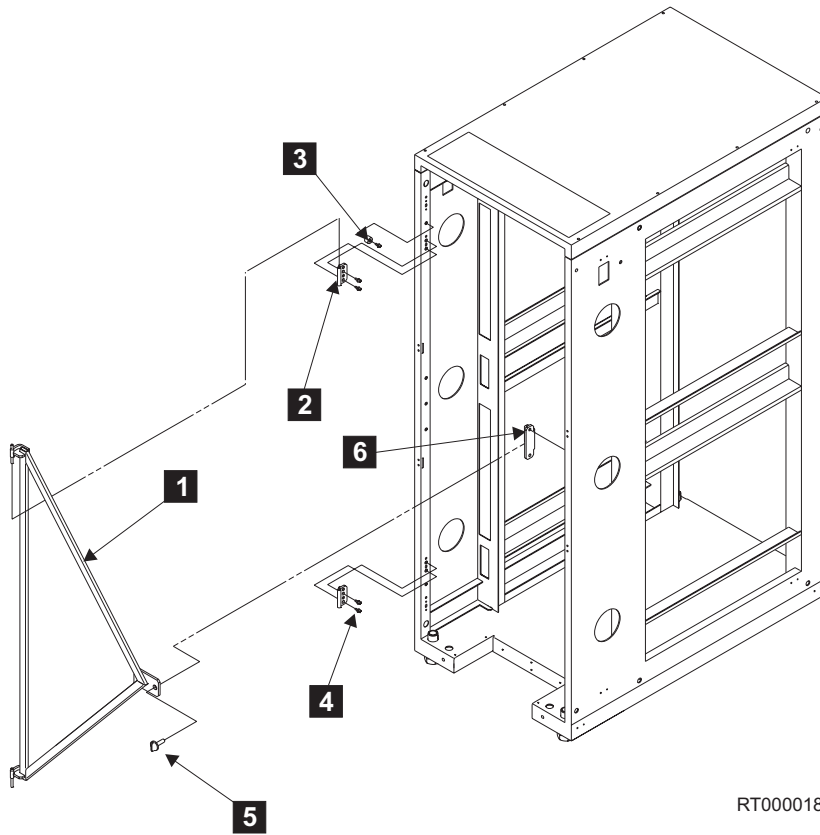

RT000018

Index number	FRU part number	Units per assembly	Description
	05N4697	1	Earthquake brace kit
1	Reference only	1	Bracket
2	Reference only	2	Hinge
3	Reference only	1	Spacer
4	Reference only	7	Screw
5	Reference only	1	Bolt
6	Reference only	1	Latch plate

Blank fillers

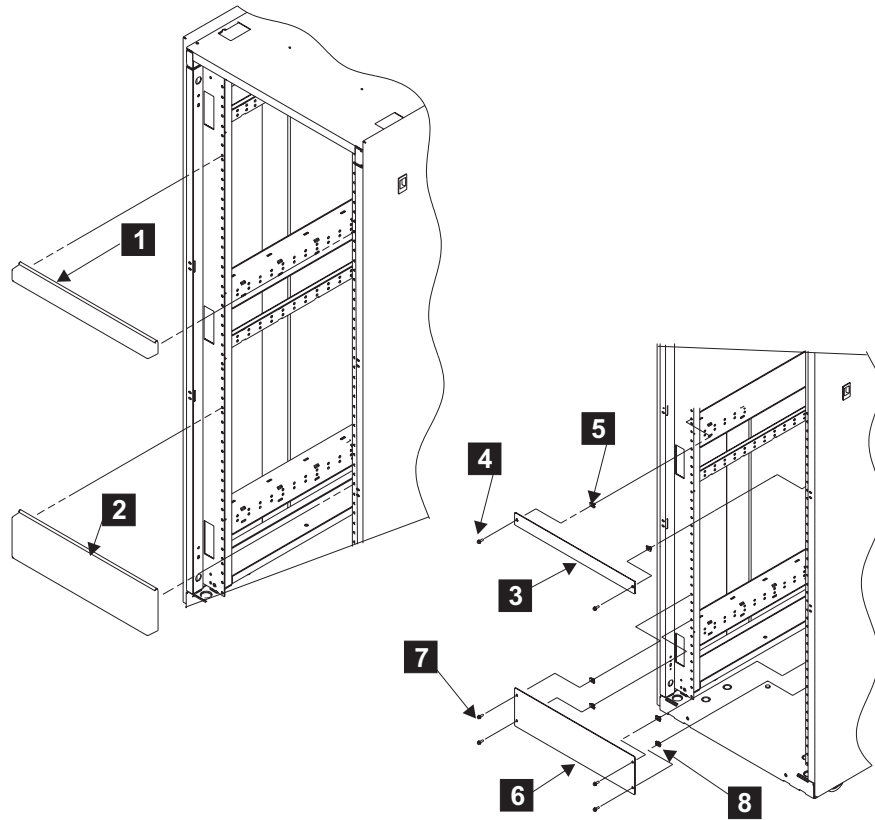

RT000019

Index number	FRU part number	Units per assembly	Description
1	97H9754	As needed	1U (black) Filler snap
2	97H9755	As needed	3U (black) Filler snap
	18P2265	As needed	1U Bolt in panel kit, (black)
3	Reference only	1	Panel (1U kit)
4	Reference only	2	M5 X 14 Hex screw (1U kit)
5	Reference only	2	M5 Nut clip (1U kit)
	18P2233	As needed	3U Bolt in panel kit, (black)
6	Reference only	1	Panel (3U kit)
7	Reference only	4	M5 X 14 Hex screw (3U kit)
8	Reference only	4	M5 Nut clip (3U kit)

Power distribution unit (PDU)

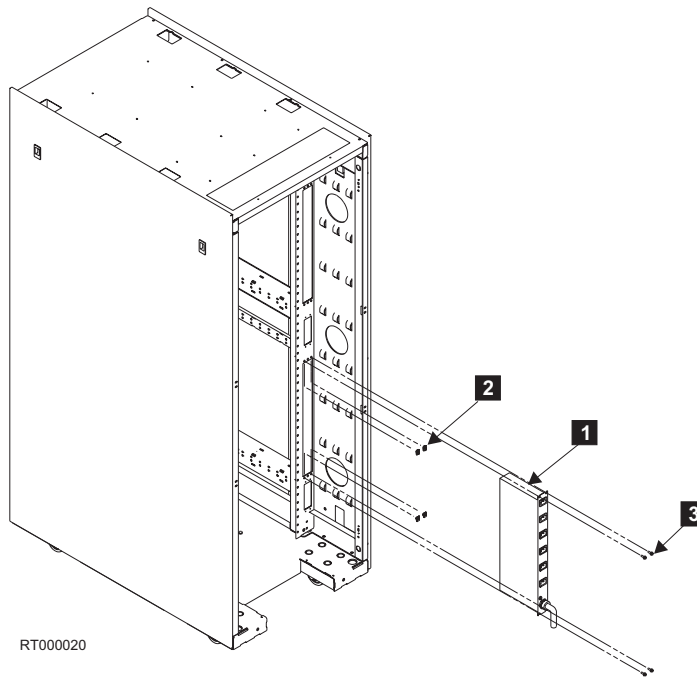

Index number	FRU part number	Units per assembly	Description
1	00P2200	1	Type 6 power distribution unit (1 phase US)
1	26K4247	1	9188/7188 power distribution unit ¹
2	1624779	4	Nut clip (for Type 6 PDU)
3	74F1823	4	Screw (for Type 6 PDU)

1. The 9188/7188 PDU does not ship with the nut clips, screws, L-shaped brackets, or bracket mounting screws required to mount the 9188/7188 PDU in the rack. If you are replacing a failed PDU with a 9188/7188 PDU, you must keep the four screws and four nut clips that secured the failed PDU to the rack. You must also remove the two L-shaped brackets and four bracket mounting screws from the failed PDU and replace them on the replacement 9188/7188 PDU before mounting the replacement 9188/7188 PDU.

The following part numbers describe the mounting hardware for the 9188/7188 PDU. These part numbers are included for reference only.

- 90P4895 — 9188/7188 PDU L-shaped brackets
- 01N6416 — 9188/7188 PDU screws for mounting the L-shaped bracket to the PDU
- 12J5289 — 9188/7188 PDU screws for securing the PDU to the rack
- 90P4895 — 9188/7188 PDU nut clips (used with 12J5289). The nut clips attach to the rack.

Stabilizers

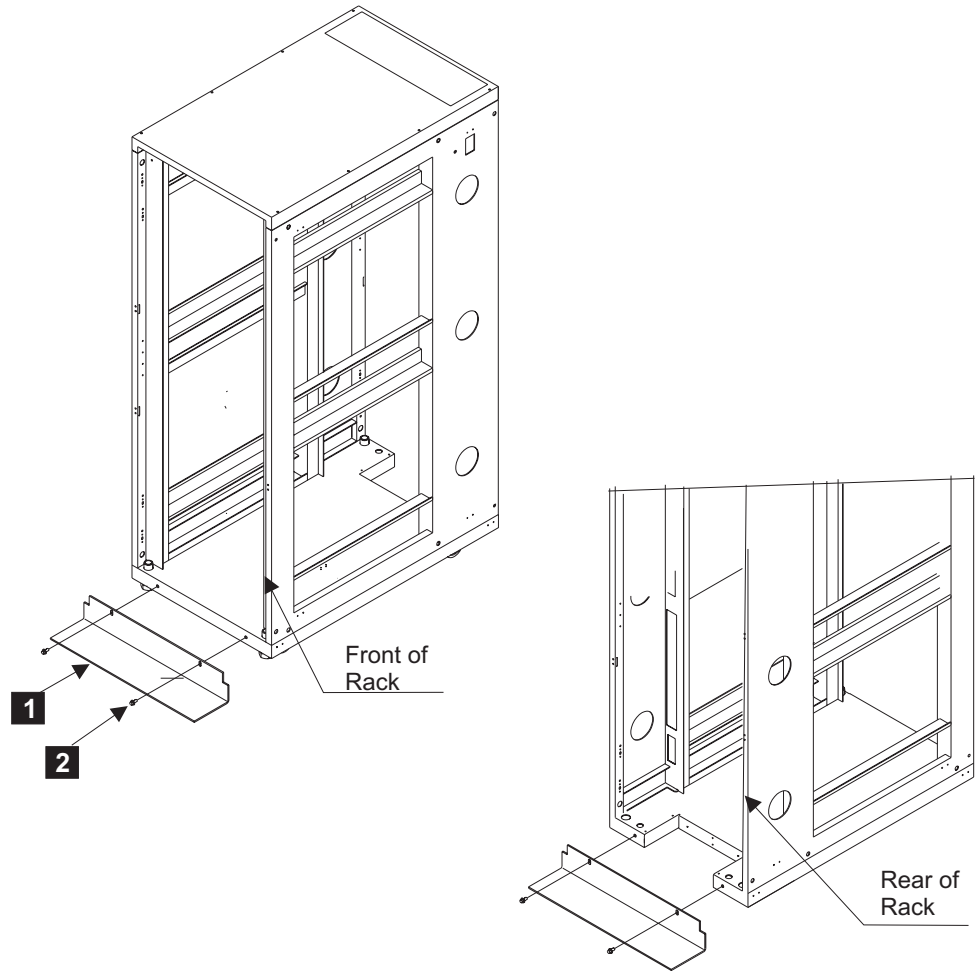

RT000021

Index number	FRU part number	Units per assembly	Description
	31L8305	1	Stabilizer kit (black)
1	Reference only	2	Bracket
2	Reference only	4	M8 X 25 screw, button head socket

Leveling feet

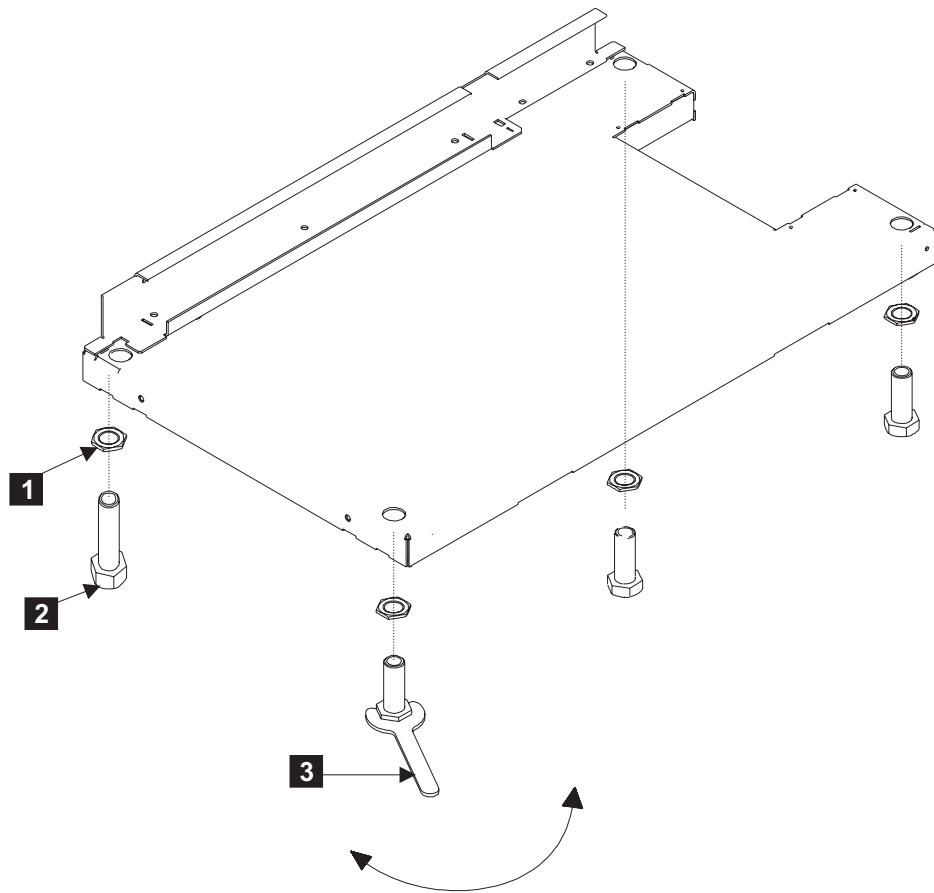

RT000023

Index number	FRU part number	Units per assembly	Description
1	Reference only	4	Jam nut
2	Reference only	4	Leveller
3	31L8313	1	Wrench

Power cords

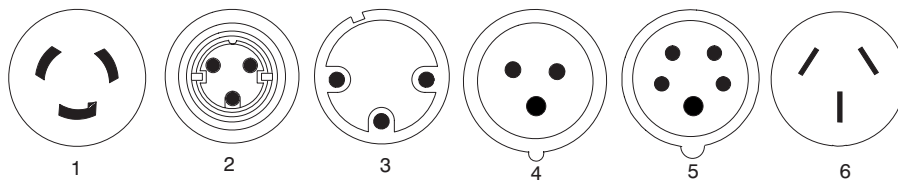

RT000024

Table 1 on page 35 lists the power cord FRUs and country and region information for the Type 6 PDU.

Table 1. Power cord FRU Index for Type 6 PDU

Index number	FRU part number	Units per assembly	Country or region
1	11F0113	1	U.S. Standard, type 12 plug, L6-30P twist-lock connector, 14-foot cord 30A, single-phase U.S.A., Canada Anguilla, Antigua, Cape Verde Islands, Cayman Islands, French Polynesia, Honduras, Montserrat, St. Kitts and Nevis, Tortola
1	11F0114	1	U.S., Chicago, type 12 plug, L6-30P twist-lock connector, 6-foot cord 30A, single-phase Chicago, Illinois, U.S.A.
1	11F0115	1	AFE, type 12 plug, L6-30P twist-lock connector, 14-foot cord 30A, single-phase Argentina, Bahamas, Bangladesh, Barbados, Bermuda, Bolivia, Chile, Colombia, Costa Rica, Dominican Republic, Ecuador, El Salvador, Guatemala, Guyana, Honduras, China (Hong Kong S.A.R.), India, Indonesia, Jamaica, Japan, China (Macau S.A.R.), Malaysia, Mexico, Myanmar, Netherlands Antilles, Panama, Peoples Republic of China, Peru, Philippines, Singapore, Sri Lanka, Suriname, Taiwan, Thailand, Trinidad, Venezuela
N/A	18P2257	1	Universal W/O Wall Plug Connector (non-US or CAN)
3	11F0106	1	30A, single-phase, PDL connector Wilco WP, type PDL plug, 14-foot cord Australia
3	11F0107	1	30 A, single-phase, PDL connector Wilco WP, type PDL plug, right angle, 14-foot cord New Zealand

Table 1. Power cord FRU Index for Type 6 PDU (continued)

Index number	FRU part number	Units per assembly	Country or region
4	31F4466	1	32A, single-phase, three-pin connector IEC 309, type 46 connector (2 power + ground), 14-foot cord Belgium, Bahrain, Botswana, Brazil, Egypt, Ethiopia, France, Ghana, Germany, Greece, Iceland, Iraq, Ireland, Italy, Jordan, Kenya, Kuwait, Lebanon, Malawi, Nigeria, Norway, Oman, Qatar, Saudi Arabia, Spain, Sudan, Tanzania, Uganda, United Kingdom, United Arab Emirates, Zaire, Zambia, Zimbabwe
5	18P2269	1	16A, 3-phase, five-pin connector IEC 309, type 46 connector (3 power + neutral + ground), 14-foot cord Switzerland
6	87G6067	1	30A, single-phase Type KP connector, right angle, 14-foot cord Korea

Table 2 lists the power cord FRUs and country and region information for the 9188/7188 PDU.

Table 2. Power cord FRU Index for 9188/7188 PDU

Index number	FRU part number	Units per assembly	Country or region
1	22R2555	1	Linecord, single-phase, PDU to wall, 14-foot (200-240V/24A, UTG0247, PT#12)
3	22R2558	1	Linecord, single-phase, PDU to wall, 14-foot (200-240V/24A, UTG0247, PT#PDL)
4	22R2553	1	Linecord, single-phase, PDU to wall, 14-foot (200-240V/24A, UTG0247, IEC309 32A P+N+G)
6	22R2559	1	Linecord, single-phase, PDU to wall, 14-foot (200-240V/24A, UTG0247, PT#KP)

2101 Model 200 rack specifications

Height: 1785 mm (70.3 in.)

Depth:

With rear door installed: 1042 mm (41 in.)

With rear and front door installed: 1098 mm (43.3 in.)

Width:

With side panels installed: 650 mm (25.6 in.)

Without side panel installed: 623 mm (24.5 in.)

EIA units: 36 EIA units

Weight:

Base Empty Rack: 244 kg (535 lbs)

Full Rack: 816 kg (1795 lbs)

Hardware warranty

This chapter contains information on IBM product warranties and liability.

Statement of limited warranty

International Business Machines Corporation
Armonk, New York, 10504

The warranties provided by IBM in this Statement of Limited Warranty¹ apply only to Machines you originally purchase for your use, and not for resale, from IBM or your reseller. The term "Machine" means an IBM machine, its features, conversions, upgrades, elements, or accessories, or any combination of them.

Unless IBM specifies otherwise, the following warranties apply only in the country where you acquire the Machine. If you have any questions, contact IBM or your reseller.

Machine: 2101 Model 200

Warranty Period: One Year *

**Contact your place of purchase for warranty service information.*

Production status

Each Machine is manufactured from new parts, or new and used parts. In some cases, the Machine may not be new and may have been previously installed. Regardless of the Machine's production status, IBM's warranty terms apply.

IBM warranty for machines

IBM warrants that each Machine 1) is free from defects in materials and workmanship and 2) conforms to IBM's Official Published Specifications. The warranty period for a Machine is a specified, fixed period commencing on its Date of Installation. The date on your receipt is the Date of Installation, unless IBM or your reseller informs you otherwise.

During the warranty period IBM or your reseller, if authorized by IBM, will provide warranty service under the type of service designated for the Machine and will manage and install engineering changes that apply to the Machine.

For IBM or your reseller to provide warranty service for a feature, conversion, or upgrade, IBM or your reseller may require that the Machine on which it is installed be 1) for certain Machines, the designated, serial-numbered Machine and 2) at an engineering-change level compatible with the feature, conversion, or upgrade. Many of these transactions involve the removal of parts and their return to IBM. You represent that all removed parts are genuine and unaltered. A part that replaces a removed part will assume the warranty service status of the replaced part.

If a Machine does not function as warranted during the warranty period, IBM or your reseller will repair it or replace it with one that is at least functionally

1. Form Z125-4753

equivalent, without charge. The replacement may not be new, but will be in good working order. If IBM or your reseller is unable to repair or replace the Machine, you may return it to your place of purchase and your money will be refunded.

If you transfer a Machine to another user, warranty service is available to that user for the remainder of the warranty period. You should give your proof of purchase and this Statement to that user. However, for Machines which have a lifetime warranty, this warranty is not transferable.

Warranty service

To obtain warranty service for the Machine, you should contact your reseller or call IBM. In the United States, call IBM at **1-800-IBM-SERV (426-7378)**. In Canada, call IBM at **1-800-465-6666**. You might be required to present proof of purchase.

IBM or your reseller will provide certain types of repair and exchange service, either at your location or at IBM's or your reseller's service center, to restore a Machine to good working order.

When a type of service involves the exchange of a Machine or part, the item IBM or your reseller replaces becomes its property and the replacement becomes yours. You represent that all removed items are genuine and unaltered. The replacement may not be new, but will be in good working order and at least functionally equivalent to the item replaced. The replacement assumes the warranty service status of the replaced item. Before IBM or your reseller exchanges a Machine or part, you agree to remove all features, parts, options, alterations, and attachments not under warranty service. You also agree to ensure that the Machine is free of any legal obligations or restrictions that prevent its exchange.

You agree to:

1. Obtain authorization from the owner to have IBM or your reseller service a Machine that you do not own; and
2. Where applicable, before service is provided:
 - a. Follow the problem determination, problem analysis, and service request procedures that IBM or your reseller provide,
 - b. Secure all programs, data, and funds contained in a Machine, and
 - c. Inform IBM or your reseller of changes in a Machine's location.

IBM is responsible for loss of, or damage to, your Machine while it is 1) in IBM's possession or 2) in transit in those cases where IBM is responsible for the transportation charges.

Extent of warranty

IBM does not warrant uninterrupted or error-free operation of a Machine.

The warranties might be voided by misuse, accident, modification, unsuitable physical or operating environment, improper maintenance by you, removal or alteration of Machine or parts identification labels, or failure caused by a product for which IBM is not responsible.

THESE WARRANTIES REPLACE ALL OTHER WARRANTIES OR CONDITIONS, EXPRESS OR IMPLIED, INCLUDING, BUT NOT LIMITED TO, THE IMPLIED WARRANTIES OR CONDITIONS OF MERCHANTABILITY AND FITNESS FOR A PARTICULAR PURPOSE. THESE WARRANTIES GIVE YOU SPECIFIC LEGAL RIGHTS AND YOU MAY ALSO HAVE OTHER RIGHTS WHICH VARY FROM

JURISDICTION TO JURISDICTION. SOME JURISDICTIONS DO NOT ALLOW THE EXCLUSION OR LIMITATION OF EXPRESS OR IMPLIED WARRANTIES, SO THE ABOVE EXCLUSION OR LIMITATION MAY NOT APPLY TO YOU. IN THAT EVENT SUCH WARRANTIES ARE LIMITED IN DURATION TO THE WARRANTY PERIOD. NO WARRANTIES APPLY AFTER THAT PERIOD.

Limitation of liability

Circumstances might arise where, because of a default on IBM's part or other liability, you are entitled to recover damages from IBM. In each such instance, regardless of the basis on which you are entitled to claim damages from IBM (including fundamental breach, negligence, misrepresentation, or other contract or tort claim), IBM is liable only for:

1. Damages for bodily injury (including death) and damage to real property and tangible personal property; and
2. The amount of any other actual direct damages or loss, up to the greater of U.S. \$100,000 or the charges (if recurring, 12 months' charges apply) for the Machine that is the subject of the claim.

UNDER NO CIRCUMSTANCES IS IBM LIABLE FOR ANY OF THE FOLLOWING: 1) THIRD-PARTY CLAIMS AGAINST YOU FOR LOSSES OR DAMAGES (OTHER THAN THOSE UNDER THE FIRST ITEM LISTED ABOVE); 2) LOSS OF, OR DAMAGE TO, YOUR RECORDS OR DATA; OR 3) SPECIAL, INCIDENTAL, OR INDIRECT DAMAGES OR FOR ANY ECONOMIC CONSEQUENTIAL DAMAGES (INCLUDING LOST PROFITS OR SAVINGS), EVEN IF IBM OR YOUR RESELLER IS INFORMED OF THEIR POSSIBILITY. SOME JURISDICTIONS DO NOT ALLOW THE EXCLUSION OR LIMITATION OF INCIDENTAL OR CONSEQUENTIAL DAMAGES, SO THE ABOVE EXCLUSION OR LIMITATION MAY NOT APPLY TO YOU.

Notices

This information was developed for products and services offered in the U.S.A.

IBM may not offer the products, services, or features discussed in this document in other countries. Consult your local IBM representative for information on the products and services currently available in your area. Any reference to an IBM product, program, or service is not intended to state or imply that only that IBM product, program, or service may be used. Any functionally equivalent product, program, or service that does not infringe any IBM intellectual property right may be used instead. However, it is the user's responsibility to evaluate and verify the operation of any non-IBM product, program, or service.

IBM may have patents or pending patent applications covering subject matter described in this document. The furnishing of this document does not give you any license to these patents. You can send license inquiries, in writing, to:

*IBM Director of Licensing
IBM Corporation
North Castle Drive
Armonk, NY 10504-1785
U.S.A.*

The following paragraph does not apply to the United Kingdom or any other country where such provisions are inconsistent with local law:

INTERNATIONAL BUSINESS MACHINES CORPORATION PROVIDES THIS PUBLICATIONS "AS IS" WITHOUT WARRANTY OF ANY KIND, EITHER EXPRESS OR IMPLIED, INCLUDING, BUT NOT LIMITED TO, THE IMPLIED WARRANTIES OF NON-INFRINGEMENT, MERCHANTABILITY OR FITNESS FOR A PARTICULAR PURPOSE. Some states do not allow disclaimer of express or implied warranties in certain transactions, therefore, this statement may not apply to you.

This information could include technical inaccuracies or typographical errors. Changes are periodically made to the information herein; these changes will be incorporated in new editions of the publications. IBM may make improvements and/or changes in the product(s) and/or program(s) described in this publication at any time without notice.

Any references in this information to non-IBM Web sites are provided for convenience only and do not in any manner serve as an endorsement of those Web sites. The materials at those Web sites are not part of the materials for this IBM product and use of those Web sites is at your own risk.

IBM may use or distribute any of the information you supply in any way it believes appropriate without incurring any obligation to you.

Trademarks

The following terms are trademarks of the International Business Machines Corporation in the United States, other countries, or both:

IBM
IBMLink
IntelliStation
pSeries
TotalStorage
xSeries

Other company, product, and service names may be trademarks or service marks of others.

Electronic emission statements

This section gives the electronic emission notices or statements for the United States and other countries.

Federal Communications Commission (FCC) statement

This equipment has been tested and found to comply with the limits for a class A digital device, pursuant to Part 15 of the FCC Rules. These limits are designed to provide reasonable protection against harmful interference when the equipment is operated in a commercial environment. This equipment generates, uses, and can radiate radio frequency energy and, if not installed and used in accordance with the instruction manual, may cause harmful interference to radio communications. Operation of this equipment in a residential area is likely to cause harmful interference, in which case the user will be required to correct the interference at his own expense.

Properly shielded and grounded cables and connectors must be used in order to meet FCC emission limits. IBM is not responsible for any radio or television interference caused by using other than recommended cables and connectors or by unauthorized changes or modifications to this equipment. Unauthorized changes or modifications could void the user's authority to operate the equipment.

This device complies with Part 15 of the FCC Rules. Operation is subject to the following two conditions: (1) this device may not cause harmful interference, and (2) this device must accept any interference received, including interference that may cause undesired operation.

Industry Canada compliance statement

Avis de conformité a la réglementation d'Industrie Canada: Cet appareil numérique de la classe A est conforme a la norme NMB-003 du Canada.

European community compliance statement

This product is in conformity with the protection requirements of EC Council Directive 89/336/EEC on the approximation of the laws of the Member States relating to electromagnetic compatibility. IBM cannot accept responsibility for any failure to satisfy the protection requirements resulting from a non-recommended modification of the product, including the fitting of non-IBM option cards.

This product has been tested and found to comply with the limits for Class A Information Technology Equipment according to European Standard EN 55022. The limits for Class A equipment were derived for commercial and industrial environments to provide reasonable protection against interference with licensed communication equipment.

Attention: This is a Class A product. In a domestic environment, this product may cause radio interference in which case the user may be required to take adequate measures.

Where shielded or special cables (for example, cables fitted with ferrites) are used in the test to make the product comply with the limits:

Properly shielded and grounded cables and connectors must be used in order to reduce the potential for causing interference to radio and TV communications and to other electrical or electronic equipment. Such cables and connectors are available from IBM authorized dealers. IBM cannot accept responsibility for any interference caused by using other than recommended cables and connectors.

This product is in conformity with the EU council directive 73/23/EEC on the approximation of the laws of the Member States relating to electrical equipment designed for use within certain voltage limits. This conformity is based on compliance with the following harmonized standard: EN60950.

Germany compliance statement

Zulassungsbescheinigung laut Gesetz ueber die elektromagnetische Vertraeglichkeit von Geraeten (EMVG) vom 30. August 1995.

Dieses Geraet ist berechtigt, in Uebereinstimmung mit dem deutschen EMVG das EG-Konformitaetszeichen - CE - zu fuehren.

Der Aussteller der Konformitaetserklaeung ist die IBM Deutschland.

Informationen in Hinsicht EMVG Paragraph 3 Abs. (2) 2:

Das Geraet erfuehlt die Schutzanforderungen nach EN 50082-1 und EN 55022 Klasse A.

EN 55022 Klasse A Geraete beduerfen folgender Hinweise:

Nach dem EMVG:

"Geraete duerfen an Orten, fuer die sie nicht ausreichend entstoert sind, nur mit besonderer Genehmigung des Bundesministeriums fuer Post und Telekommunikation oder des Bundesamtes fuer Post und Telekommunikation betrieben werden. Die Genehmigung wird erteilt, wenn keine elektromagnetischen Stoerungen zu erwarten sind." (Auszug aus dem EMVG, Paragraph 3, Abs.4)

Dieses Genehmigungsverfahren ist nach Paragraph 9 EMVG in Verbindung mit der entsprechenden Kostenverordnung (Amtsblatt 14/93) kostenpflichtig.

Nach der EN 55022:

"Dies ist eine Einrichtung der Klasse A. Diese Einrichtung kann im Wohnbereich Funkstoerungen verursachen in diesem Fall kann vom Betreiber verlangt werden, angemessene Massnahmen durchzufuehren und dafuer aufzukommen."

Anmerkung:

Um die Einhaltung des EMVG sicherzustellen, sind die Geraete wie in den Handbuechern angegeben zu installieren und zu betreiben.

Japanese Voluntary Control Council for Interference (VCCI) class 1 statement

この装置は、情報処理装置等電波障害自主規制協議会（VCCI）の基準に基づくクラス A 情報技術装置です。この装置を家庭環境で使用すると電波妨害を引き起こすことがあります。この場合には使用者が適切な対策を講ずるよう要求されることがあります。

Korean Government Ministry of Communication (MOC) statement

Please note that this device has been approved for business purposes with regard to electromagnetic interference. If you find that this is not suitable for your use, you may exchange it for one with a non-business use.

Taiwan class A compliance statement

警告使用者:

這是甲類的資訊產品，在居住的環境中使用時，可能會造成射頻干擾，在這種情況下，使用者會被要求採取某些適當的對策。

RT000027

Glossary

This glossary provides definitions for the terminology and abbreviations used in this document.

If you do not find the term you are looking for, see the *IBM Glossary of Computing Terms* located at the following Web site:

www.ibm.com/ibm/terminology

This glossary also includes terms and definitions from:

- *Information Technology Vocabulary* by Subcommittee 1, Joint Technical Committee 1, of the International Organization for Standardization and the International Electrotechnical Commission (ISO/IEC JTC1/SC1). Definitions are identified by the symbol (I) after the definition; definitions taken from draft international standards, committee drafts, and working papers by ISO/IEC JTC1/SC1 are identified by the symbol (T) after the definition, indicating that final agreement has not yet been reached among the participating National Bodies of SC1.
- *IBM Glossary of Computing Terms*. New York: McGraw-Hill, 1994.

The following cross-reference conventions are used in this glossary:

See Refers you to (a) a term that is the expanded form of an abbreviation or acronym, or (b) a synonym or more preferred term.

See also
Refers you to a related term.

Abstract Windowing Toolkit (AWT). A Java graphical user interface (GUI).

accelerated graphics port (AGP). A bus specification that gives low-cost 3D graphics cards faster access to main memory on personal computers than the usual peripheral component interconnect (PCI) bus. AGP reduces the overall cost of creating high-end graphics subsystems by using existing system memory.

access volume. A special logical drive that allows the host-agent to communicate with the controllers in the storage subsystem.

adapter. A printed circuit assembly that transmits user data input/output (I/O) between the internal bus of the host system and the external fibre-channel (FC) link and vice versa. Also called an I/O adapter, host adapter, or FC adapter.

advanced technology (AT) bus architecture. A bus standard for IBM compatibles. It extends the XT bus architecture to 16 bits and also allows for bus mastering, although only the first 16 MB of main memory are available for direct access.

agent. A server program that receives virtual connections from the network manager (the client program) in a Simple Network Management Protocol-Transmission Control Protocol/Internet Protocol (SNMP-TCP/IP) network-managing environment.

AGP. See *accelerated graphics port*.

AL_PA. See *arbitrated loop physical address*.

arbitrated loop. One of three existing fibre-channel topologies, in which 2 - 126 ports are interconnected serially in a single loop circuit. Access to the Fibre Channel-Arbitrated Loop (FC-AL) is controlled by an arbitration scheme. The FC-AL topology supports all classes of service and guarantees in-order delivery of FC frames when the originator and responder are on the same FC-AL. The default topology for the disk array is arbitrated loop. An arbitrated loop is sometimes referred to as a Stealth Mode.

arbitrated loop physical address (AL_PA). An 8-bit value that is used to uniquely identify an individual port within a loop. A loop can have one or more AL_PAs.

array. A collection of fibre-channel or SATA hard drives that are logically grouped together. All the drives in the array are assigned the same RAID level. An array is sometimes referred to as a "RAID set." See also *redundant array of independent disks (RAID)*, *RAID level*.

asynchronous write mode. In remote mirroring, an option that allows the primary controller to return a write I/O request completion to the host server before data has been successfully written by the secondary controller. See also *synchronous write mode*, *remote mirroring*, *Global Copy*, *Global Mirroring*.

AT. See *advanced technology (AT) bus architecture*.

ATA. See *AT-attached*.

AT-attached. Peripheral devices that are compatible with the original IBM AT computer standard in which signals on a 40-pin AT-attached (ATA) ribbon cable followed the timings and constraints of the Industry Standard Architecture (ISA) system bus on the IBM PC AT computer. Equivalent to integrated drive electronics (IDE).

auto-volume transfer/auto-disk transfer (AVT/ADT). A function that provides automatic failover in case of controller failure on a storage subsystem.

AVT/ADT. See *auto-volume transfer/auto-disk transfer*.

AWT. See *Abstract Windowing Toolkit*.

basic input/output system (BIOS). The personal computer code that controls basic hardware operations, such as interactions with diskette drives, hard disk drives, and the keyboard.

BIOS. See *basic input/output system*.

BOOTP. See *bootstrap protocol*.

bootstrap protocol (BOOTP). In Transmission Control Protocol/Internet Protocol (TCP/IP) networking, an alternative protocol by which a diskless machine can obtain its Internet Protocol (IP) address and such configuration information as IP addresses of various servers from a BOOTP server.

bridge. A storage area network (SAN) device that provides physical and transport conversion, such as fibre channel to small computer system interface (SCSI) bridge.

bridge group. A bridge and the collection of devices connected to it.

broadcast. The simultaneous transmission of data to more than one destination.

cathode ray tube (CRT). A display device in which controlled electron beams are used to display alphanumeric or graphical data on an electroluminescent screen.

client. A computer system or process that requests a service of another computer system or process that is typically referred to as a server. Multiple clients can share access to a common server.

command. A statement used to initiate an action or start a service. A command consists of the command name abbreviation, and its parameters and flags if applicable. A command can be issued by typing it on a command line or selecting it from a menu.

community string. The name of a community contained in each Simple Network Management Protocol (SNMP) message.

concurrent download. A method of downloading and installing firmware that does not require the user to stop I/O to the controllers during the process.

CRC. See *cyclic redundancy check*.

CRT. See *cathode ray tube*.

CRU. See *customer replaceable unit*.

customer replaceable unit (CRU). An assembly or part that a customer can replace in its entirety when any of its components fail. Contrast with *field replaceable unit (FRU)*.

cyclic redundancy check (CRC). (1) A redundancy check in which the check key is generated by a cyclic algorithm. (2) An error detection technique performed at both the sending and receiving stations.

dac. See *disk array controller*.

dar. See *disk array router*.

DASD. See *direct access storage device*.

data striping. See *striping*.

default host group. A logical collection of discovered host ports, defined host computers, and defined host groups in the storage-partition topology that fulfill the following requirements:

- Are not involved in specific logical drive-to-LUN mappings
- Share access to logical drives with default logical drive-to-LUN mappings

device type. Identifier used to place devices in the physical map, such as the switch, hub, or storage.

DHCP. See *Dynamic Host Configuration Protocol*.

direct access storage device (DASD). A device in which access time is effectively independent of the location of the data. Information is entered and retrieved without reference to previously accessed data. (For example, a disk drive is a DASD, in contrast with a tape drive, which stores data as a linear sequence.) DASDs include both fixed and removable storage devices.

direct memory access (DMA). The transfer of data between memory and an input/output (I/O) device without processor intervention.

disk array controller (dac). A disk array controller device that represents the two controllers of an array. See also *disk array router*.

disk array router (dar). A disk array router that represents an entire array, including current and deferred paths to all logical unit numbers (LUNs) (hdisks on AIX). See also *disk array controller*.

DMA. See *direct memory access*.

domain. The most significant byte in the node port (N_port) identifier for the fibre-channel (FC) device. It is not used in the fibre channel-small computer system interface (FC-SCSI) hardware path ID. It is required to be the same for all SCSI targets logically connected to an FC adapter.

DRAM. See *dynamic random access memory*.

Dynamic Host Configuration Protocol (DHCP). A protocol defined by the Internet Engineering Task Force that is used for dynamically assigning Internet Protocol (IP) addresses to computers in a network.

dynamic random access memory (DRAM). A storage in which the cells require repetitive application of control signals to retain stored data.

ECC. See *error correction coding*.

EEPROM. See *electrically erasable programmable read-only memory*.

EISA. See *Extended Industry Standard Architecture*.

electrically erasable programmable read-only memory (EEPROM). A type of memory chip which can retain its contents without consistent electrical power. Unlike the PROM which can be programmed only once, the EEPROM can be erased electrically. Because it can only be reprogrammed a limited number of times before it wears out, it is appropriate for storing small amounts of data that are changed infrequently.

electrostatic discharge (ESD). The flow of current that results when objects that have a static charge come into close enough proximity to discharge.

environmental service module (ESM) canister. A component in a storage expansion enclosure that monitors the environmental condition of the components in that enclosure. Not all storage subsystems have ESM canisters.

E_port. See *expansion port*.

error correction coding (ECC). A method for encoding data so that transmission errors can be detected and corrected by examining the data on the receiving end. Most ECCs are characterized by the maximum number of errors they can detect and correct.

ESD. See *electrostatic discharge*.

ESM canister. See *environmental service module canister*.

EXP. See *storage expansion enclosure*.

expansion port (E_port). A port that connects the switches for two fabrics.

Extended Industry Standard Architecture (EISA). A bus standard for IBM compatibles that extends the Industry Standard Architecture (ISA) bus architecture to 32 bits and allows more than one central processing unit (CPU) to share the bus. See also *Industry Standard Architecture*.

fabric. A Fibre Channel entity which interconnects and facilitates logins of N_ports attached to it. The fabric is responsible for routing frames between source and destination N_ports using address information in the frame header. A fabric can be as simple as a point-to-point channel between two N_ports, or as complex as a frame-routing switch that provides multiple and redundant internal pathways within the fabric between F_ports.

fabric port (F_port). In a fabric, an access point for connecting a user's N_port. An F_port facilitates N_port logins to the fabric from nodes connected to the fabric. An F_port is addressable by the N_port connected to it. See also *fabric*.

FAST MSJ. See *FAST Management Suite Java*.

FAST Management Suite Java (FAST MSJ). A diagnostic and configuration utility that can be used on Linux, Microsoft Windows, and Novell NetWare host systems. In Linux, it is also used with the QLRemote agent to define preferred and non-preferred paths for logical drives.

FC. See *fibre channel*.

FC-AL. See *arbitrated loop*.

feature enable identifier. A unique identifier for the storage subsystem, which is used in the process of generating a premium feature key. See also *premium feature key*.

fibre channel (FC). A set of standards for a serial input/output (I/O) bus capable of transferring data between two ports at up to 100 Mbps, with standards proposals to go to higher speeds. FC supports point-to-point, arbitrated loop, and switched topologies.

Fibre Channel-Arbitrated Loop (FC-AL). See *arbitrated loop*.

Fibre Channel Protocol (FCP) for small computer system interface (SCSI). A high-level fibre-channel mapping layer (FC-4) that uses lower-level fibre-channel (FC-PH) services to transmit SCSI commands, data, and status information between a SCSI initiator and a SCSI target across the FC link by using FC frame and sequence formats.

field replaceable unit (FRU). An assembly that is replaced in its entirety when any one of its components fails. In some cases, a field replaceable unit might contain other field replaceable units. Contrast with *customer replaceable unit (CRU)*.

FlashCopy. A premium feature for DS4000 that can make an instantaneous copy of the data in a volume.

F_port. See *fabric port*.

FRU. See *field replaceable unit*.

GBIC. See *gigabit interface converter*

gigabit interface converter (GBIC). A transceiver that performs serial, optical-to-electrical, and electrical-to-optical signal conversions for high-speed networking. A GBIC can be hot swapped. See also *small form-factor pluggable*.

Global Copy. Refers to a remote logical drive mirror pair that is set up using asynchronous write mode without the write consistency group option. This is also referred to as "Asynchronous Mirroring without Consistency Group." Global Copy does not ensure that write requests to multiple primary logical drives are carried out in the same order on the secondary logical drives as they are on the primary logical drives. If it is critical that writes to the primary logical drives are carried out in the same order in the appropriate secondary logical drives, Global Mirroring should be used instead of Global Copy. See also *asynchronous write mode*, *Global Mirroring*, *remote mirroring*, *Metro Mirroring*.

Global Mirroring. Refers to a remote logical drive mirror pair that is set up using asynchronous write mode with the write consistency group option. This is also referred to as "Asynchronous Mirroring with Consistency Group." Global Mirroring ensures that write requests to multiple primary logical drives are carried out in the same order on the secondary logical drives as they are on the primary logical drives, preventing data on the secondary logical drives from becoming inconsistent with the data on the primary logical drives. See also *asynchronous write mode*, *Global Copy*, *remote mirroring*, *Metro Mirroring*.

graphical user interface (GUI). A type of computer interface that presents a visual metaphor of a real-world scene, often of a desktop, by combining high-resolution graphics, pointing devices, menu bars and other menus, overlapping windows, icons, and the object-action relationship.

GUI. See *graphical user interface*.

HBA. See *host bus adapter*.

hdisk. An AIX term representing a logical unit number (LUN) on an array.

host. A system that is directly attached to the storage subsystem through a fibre-channel input/output (I/O) path. This system is used to serve data (typically in the form of files) from the storage subsystem. A system can be both a storage management station and a host simultaneously.

host bus adapter (HBA). An interface between the fibre-channel network and a workstation or server.

host computer. See *host*.

host group. An entity in the storage partition topology that defines a logical collection of host computers that require shared access to one or more logical drives.

host port. Ports that physically reside on the host adapters and are automatically discovered by the DS4000 Storage Manager software. To give a host computer access to a partition, its associated host ports must be defined.

hot swap. To replace a hardware component without turning off the system.

hub. In a network, a point at which circuits are either connected or switched. For example, in a star network, the hub is the central node; in a star/ring network, it is the location of wiring concentrators.

IBMSAN driver. The device driver that is used in a Novell NetWare environment to provide multipath input/output (I/O) support to the storage controller.

IC. See *integrated circuit*.

IDE. See *integrated drive electronics*.

in-band. Transmission of management protocol over the fibre-channel transport.

Industry Standard Architecture (ISA). Unofficial name for the bus architecture of the IBM PC/XT personal computer. This bus design included expansion slots for plugging in various adapter boards. Early versions had an 8-bit data path, later expanded to 16 bits. The "Extended Industry Standard Architecture" (EISA) further expanded the data path to 32 bits. See also *Extended Industry Standard Architecture*.

initial program load (IPL). The initialization procedure that causes an operating system to commence operation. Also referred to as a system restart, system startup, and boot.

integrated circuit (IC). A microelectronic semiconductor device that consists of many interconnected transistors and other components. ICs are constructed on a small rectangle cut from a silicon crystal or other semiconductor material. The small size of these circuits allows high speed, low power dissipation, and reduced manufacturing cost compared with board-level integration. Also known as a *chip*.

integrated drive electronics (IDE). A disk drive interface based on the 16-bit IBM personal computer Industry Standard Architecture (ISA) in which the controller electronics reside on the drive itself,

eliminating the need for a separate adapter card. Also known as an Advanced Technology Attachment Interface (ATA).

Internet Protocol (IP). A protocol that routes data through a network or interconnected networks. IP acts as an intermediary between the higher protocol layers and the physical network.

Internet Protocol (IP) address. The unique 32-bit address that specifies the location of each device or workstation on the Internet. For example, 9.67.97.103 is an IP address.

interrupt request (IRQ). A type of input found on many processors that causes the processor to suspend normal processing temporarily and start running an interrupt handler routine. Some processors have several interrupt request inputs that allow different priority interrupts.

IP. See *Internet Protocol*.

IPL. See *initial program load*.

IRQ. See *interrupt request*.

ISA. See *Industry Standard Architecture*.

Java Runtime Environment (JRE). A subset of the Java Development Kit (JDK) for end users and developers who want to redistribute the Java Runtime Environment (JRE). The JRE consists of the Java virtual machine, the Java Core Classes, and supporting files.

JRE. See *Java Runtime Environment*.

label. A discovered or user entered property value that is displayed underneath each device in the Physical and Data Path maps.

LAN. See *local area network*.

LBA. See *logical block address*.

local area network (LAN). A computer network located on a user's premises within a limited geographic area.

logical block address (LBA). The address of a logical block. Logical block addresses are typically used in hosts' I/O commands. The SCSI disk command protocol, for example, uses logical block addresses.

logical partition (LPAR). (1) A subset of a single system that contains resources (processors, memory, and input/output devices). A logical partition operates as an independent system. If hardware requirements are met, multiple logical partitions can exist within a system. (2) A fixed-size portion of a logical volume. A logical partition is the same size as the physical partitions in its volume group. Unless the logical volume of which it is a part is mirrored, each logical partition corresponds to, and its contents are stored on,

a single physical partition. (3) One to three physical partitions (copies). The number of logical partitions within a logical volume is variable.

logical unit number (LUN). An identifier used on a small computer system interface (SCSI) bus to distinguish among up to eight devices (logical units) with the same SCSI ID.

loop address. The unique ID of a node in fibre-channel loop topology sometimes referred to as a loop ID.

loop group. A collection of storage area network (SAN) devices that are interconnected serially in a single loop circuit.

loop port. A node port (N_port) or fabric port (F_port) that supports arbitrated loop functions associated with an arbitrated loop topology.

LPAR. See *logical partition*.

LUN. See *logical unit number*.

MAC. See *medium access control*.

management information base (MIB). The information that is on an agent. It is an abstraction of configuration and status information.

man pages. In UNIX-based operating systems, online documentation for operating system commands, subroutines, system calls, file formats, special files, stand-alone utilities, and miscellaneous facilities. Invoked by the **man** command.

MCA. See *micro channel architecture*.

media scan. A media scan is a background process that runs on all logical drives in the storage subsystem for which it has been enabled, providing error detection on the drive media. The media scan process scans all logical drive data to verify that it can be accessed, and optionally scans the logical drive data also.

medium access control (MAC). In local area networks (LANs), the sublayer of the data link control layer that supports medium-dependent functions and uses the services of the physical layer to provide services to the logical link control sublayer. The MAC sublayer includes the method of determining when a device has access to the transmission medium.

Metro Mirroring. This term is used to refer to a remote logical drive mirror pair which is set up with synchronous write mode. See also *remote mirroring*, *Global Mirroring*.

MIB. See *management information base*.

micro channel architecture (MCA). Hardware that is used for PS/2 Model 50 computers and above to

provide better growth potential and performance characteristics when compared with the original personal computer design.

Microsoft Cluster Server (MSCS). MSCS, a feature of Windows NT Server (Enterprise Edition), supports the connection of two servers into a cluster for higher availability and easier manageability. MSCS can automatically detect and recover from server or application failures. It can also be used to balance server workload and provide for planned maintenance.

mini hub. An interface card or port device that receives short-wave fiber channel GBICs or SFPs. These devices enable redundant fibre channel connections from the host computers, either directly or through a fibre channel switch or managed hub, over optical fiber cables to the DS4000 Storage Server controllers. Each DS4000 controller is responsible for two mini hubs. Each mini hub has two ports. Four host ports (two on each controller) provide a cluster solution without use of a switch. Two host-side mini hubs are shipped as standard. See also *host port*, *gigabit interface converter (GBIC)*, *small form-factor pluggable (SFP)*.

mirroring. A fault-tolerance technique in which information on a hard disk is duplicated on additional hard disks. See also *remote mirroring*.

model. The model identification that is assigned to a device by its manufacturer.

MSCS. See *Microsoft Cluster Server*.

network management station (NMS). In the Simple Network Management Protocol (SNMP), a station that runs management application programs that monitor and control network elements.

NMI. See *non-maskable interrupt*.

NMS. See *network management station*.

non-maskable interrupt (NMI). A hardware interrupt that another service request cannot overrule (mask). An NMI bypasses and takes priority over interrupt requests generated by software, the keyboard, and other such devices and is issued to the microprocessor only in disastrous circumstances, such as severe memory errors or impending power failures.

node. A physical device that allows for the transmission of data within a network.

node port (N_port). A fibre-channel defined hardware entity that performs data communications over the fibre-channel link. It is identifiable by a unique worldwide name. It can act as an originator or a responder.

nonvolatile storage (NVS). A storage device whose contents are not lost when power is cut off.

N_port. See *node port*.

NVS. See *nonvolatile storage*.

NVSRAM. Nonvolatile storage random access memory. See *nonvolatile storage*.

Object Data Manager (ODM). An AIX proprietary storage mechanism for ASCII stanza files that are edited as part of configuring a drive into the kernel.

ODM. See *Object Data Manager*.

out-of-band. Transmission of management protocols outside of the fibre-channel network, typically over Ethernet.

partitioning. See *storage partition*.

parity check. (1) A test to determine whether the number of ones (or zeros) in an array of binary digits is odd or even. (2) A mathematical operation on the numerical representation of the information communicated between two pieces. For example, if parity is odd, any character represented by an even number has a bit added to it, making it odd, and an information receiver checks that each unit of information has an odd value.

PCI local bus. See *peripheral component interconnect local bus*.

PDF. See *portable document format*.

performance events. Events related to thresholds set on storage area network (SAN) performance.

peripheral component interconnect local bus (PCI local bus). A local bus for PCs, from Intel, that provides a high-speed data path between the CPU and up to 10 peripherals (video, disk, network, and so on). The PCI bus coexists in the PC with the Industry Standard Architecture (ISA) or Extended Industry Standard Architecture (EISA) bus. ISA and EISA boards plug into an IA or EISA slot, while high-speed PCI controllers plug into a PCI slot. See also *Industry Standard Architecture*, *Extended Industry Standard Architecture*.

polling delay. The time in seconds between successive discovery processes during which discovery is inactive.

port. A part of the system unit or remote controller to which cables for external devices (such as display stations, terminals, printers, switches, or external storage units) are attached. The port is an access point for data entry or exit. A device can contain one or more ports.

portable document format (PDF). A standard specified by Adobe Systems, Incorporated, for the electronic distribution of documents. PDF files are compact; can be distributed globally by e-mail, the Web, intranets, or CD-ROM; and can be viewed with

the Acrobat Reader, which is software from Adobe Systems that can be downloaded at no cost from the Adobe Systems home page.

premium feature key. A file that the storage subsystem controller uses to enable an authorized premium feature. The file contains the feature enable identifier of the storage subsystem for which the premium feature is authorized, and data about the premium feature. See also *feature enable identifier*.

private loop. A freestanding arbitrated loop with no fabric attachment. See also *arbitrated loop*.

program temporary fix (PTF). A temporary solution or bypass of a problem diagnosed by IBM in a current unaltered release of the program.

PTF. See *program temporary fix*.

RAID. See *redundant array of independent disks (RAID)*.

RAID level. An array's RAID level is a number that refers to the method used to achieve redundancy and fault tolerance in the array. See also *array, redundant array of independent disks (RAID)*.

RAID set. See *array*.

RAM. See *random-access memory*.

random-access memory (RAM). A temporary storage location in which the central processing unit (CPU) stores and executes its processes. Contrast with *DASD*.

RDAC. See *redundant disk array controller*.

read-only memory (ROM). Memory in which stored data cannot be changed by the user except under special conditions.

recoverable virtual shared disk (RVSD). A virtual shared disk on a server node configured to provide continuous access to data and file systems in a cluster.

redundant array of independent disks (RAID). A collection of disk drives (*array*) that appears as a single volume to the server, which is fault tolerant through an assigned method of data striping, mirroring, or parity checking. Each array is assigned a RAID level, which is a specific number that refers to the method used to achieve redundancy and fault tolerance. See also *array, parity check, mirroring, RAID level, striping*.

redundant disk array controller (RDAC). (1) In hardware, a redundant set of controllers (either active/passive or active/active). (2) In software, a layer that manages the input/output (I/O) through the active controller during normal operation and transparently reroutes I/Os to the other controller in the redundant set if a controller or I/O path fails.

remote mirroring. Online, real-time replication of data between storage subsystems that are maintained on

separate media. The Enhanced Remote Mirror Option is a DS4000 premium feature that provides support for remote mirroring. See also *Global Mirroring, Metro Mirroring*.

ROM. See *read-only memory*.

router. A computer that determines the path of network traffic flow. The path selection is made from several paths based on information obtained from specific protocols, algorithms that attempt to identify the shortest or best path, and other criteria such as metrics or protocol-specific destination addresses.

RVSD. See *recoverable virtual shared disk*.

SAI. See *Storage Array Identifier*.

SA Identifier. See *Storage Array Identifier*.

SAN. See *storage area network*.

SATA. See *serial ATA*.

scope. Defines a group of controllers by their Internet Protocol (IP) addresses. A scope must be created and defined so that dynamic IP addresses can be assigned to controllers on the network.

SCSI. See *small computer system interface*.

segmented loop port (SL_port). A port that allows division of a fibre-channel private loop into multiple segments. Each segment can pass frames around as an independent loop and can connect through the fabric to other segments of the same loop.

sense data. (1) Data sent with a negative response, indicating the reason for the response. (2) Data describing an I/O error. Sense data is presented to a host system in response to a sense request command.

serial ATA. The standard for a high-speed alternative to small computer system interface (SCSI) hard drives. The SATA-1 standard is equivalent in performance to a 10 000 RPM SCSI drive.

serial storage architecture (SSA). An interface specification from IBM in which devices are arranged in a ring topology. SSA, which is compatible with small computer system interface (SCSI) devices, allows full-duplex packet multiplexed serial data transfers at rates of 20 Mbps in each direction.

server. A functional hardware and software unit that delivers shared resources to workstation client units on a computer network.

server/device events. Events that occur on the server or a designated device that meet criteria that the user sets.

SFP. See *small form-factor pluggable*.

Simple Network Management Protocol (SNMP). In the Internet suite of protocols, a network management protocol that is used to monitor routers and attached networks. SNMP is an application layer protocol. Information on devices managed is defined and stored in the application's Management Information Base (MIB).

SL_port. See *segmented loop port*.

SMagent. The DS4000 Storage Manager optional Java-based host-agent software, which can be used on Microsoft Windows, Novell NetWare, HP-UX, and Solaris host systems to manage storage subsystems through the host fibre-channel connection.

SMclient. The DS4000 Storage Manager client software, which is a Java-based graphical user interface (GUI) that is used to configure, manage, and troubleshoot storage servers and storage expansion enclosures in a DS4000 storage subsystem. SMclient can be used on a host system or on a storage management station.

SMruntime. A Java compiler for the SMclient.

SMutil. The DS4000 Storage Manager utility software that is used on Microsoft Windows, HP-UX, and Solaris host systems to register and map new logical drives to the operating system. In Microsoft Windows, it also contains a utility to flush the cached data of the operating system for a particular drive before creating a FlashCopy.

small computer system interface (SCSI). A standard hardware interface that enables a variety of peripheral devices to communicate with one another.

small form-factor pluggable (SFP). An optical transceiver that is used to convert signals between optical fiber cables and switches. An SFP is smaller than a gigabit interface converter (GBIC). See also *gigabit interface converter*.

SNMP. See *Simple Network Management Protocol and SNMPv1*.

SNMP trap event. (1) (2) An event notification sent by the SNMP agent that identifies conditions, such as thresholds, that exceed a predetermined value. See also *Simple Network Management Protocol*.

SNMPv1. The original standard for SNMP is now referred to as SNMPv1, as opposed to SNMPv2, a revision of SNMP. See also *Simple Network Management Protocol*.

SRAM. See *static random access memory*.

SSA. See *serial storage architecture*.

static random access memory (SRAM). Random access memory based on the logic circuit known as

flip-flop. It is called static because it retains a value as long as power is supplied, unlike dynamic random access memory (DRAM), which must be regularly refreshed. It is however, still volatile, meaning that it can lose its contents when the power is turned off.

storage area network (SAN). A dedicated storage network tailored to a specific environment, combining servers, storage products, networking products, software, and services. See also *fabric*.

Storage Array Identifier (SAI or SA Identifier). The Storage Array Identifier is the identification value used by the DS4000 Storage Manager host software (SMClient) to uniquely identify each managed storage server. The DS4000 Storage Manager SMClient program maintains Storage Array Identifier records of previously-discovered storage servers in the host resident file, which allows it to retain discovery information in a persistent fashion.

storage expansion enclosure (EXP). A feature that can be connected to a system unit to provide additional storage and processing capacity.

storage management station. A system that is used to manage the storage subsystem. A storage management station does not need to be attached to the storage subsystem through the fibre-channel input/output (I/O) path.

storage partition. Storage subsystem logical drives that are visible to a host computer or are shared among host computers that are part of a host group.

storage partition topology. In the DS4000 Storage Manager client, the Topology view of the Mappings window displays the default host group, the defined host group, the host computer, and host-port nodes. The host port, host computer, and host group topological elements must be defined to grant access to host computers and host groups using logical drive-to-LUN mappings.

striping. Splitting data to be written into equal blocks and writing blocks simultaneously to separate disk drives. Striping maximizes performance to the disks. Reading the data back is also scheduled in parallel, with a block being read concurrently from each disk then reassembled at the host.

subnet. An interconnected but independent segment of a network that is identified by its Internet Protocol (IP) address.

sweep method. A method of sending Simple Network Management Protocol (SNMP) requests for information to all the devices on a subnet by sending the request to every device in the network.

switch. A fibre-channel device that provides full bandwidth per port and high-speed routing of data by using link-level addressing.

switch group. A switch and the collection of devices connected to it that are not in other groups.

switch zoning. See *zoning*.

synchronous write mode. In remote mirroring, an option that requires the primary controller to wait for the acknowledgment of a write operation from the secondary controller before returning a write I/O request completion to the host. See also *asynchronous write mode*, *remote mirroring*, *Metro Mirroring*.

system name. Device name assigned by the vendor's third-party software.

TCP. See *Transmission Control Protocol*.

TCP/IP. See *Transmission Control Protocol/Internet Protocol*.

terminate and stay resident program (TSR program). A program that installs part of itself as an extension of DOS when it is executed.

topology. The physical or logical arrangement of devices on a network. The three fibre-channel topologies are fabric, arbitrated loop, and point-to-point. The default topology for the disk array is arbitrated loop.

TL_port. See *translated loop port*.

transceiver. A device that is used to transmit and receive data. Transceiver is an abbreviation of transmitter-receiver.

translated loop port (TL_port). A port that connects to a private loop and allows connectivity between the private loop devices and off loop devices (devices not connected to that particular TL_port).

Transmission Control Protocol (TCP). A communication protocol used in the Internet and in any network that follows the Internet Engineering Task Force (IETF) standards for internetwork protocol. TCP provides a reliable host-to-host protocol between hosts in packet-switched communication networks and in interconnected systems of such networks. It uses the Internet Protocol (IP) as the underlying protocol.

Transmission Control Protocol/Internet Protocol (TCP/IP). A set of communication protocols that provide peer-to-peer connectivity functions for both local and wide-area networks.

trap. In the Simple Network Management Protocol (SNMP), a message sent by a managed node (agent function) to a management station to report an exception condition.

trap recipient. Receiver of a forwarded Simple Network Management Protocol (SNMP) trap. Specifically, a trap receiver is defined by an Internet Protocol (IP) address and port to which traps are sent.

Presumably, the actual recipient is a software application running at the IP address and listening to the port.

TSR program. See *terminate and stay resident program*.

uninterruptible power supply. A source of power from a battery that is installed between a computer system and its power source. The uninterruptible power supply keeps the system running if a commercial power failure occurs, until an orderly shutdown of the system can be performed.

user action events. Actions that the user takes, such as changes in the storage area network (SAN), changed settings, and so on.

worldwide port name (WWPN). A unique identifier for a switch on local and global networks.

worldwide name (WWN). A globally unique 64-bit identifier assigned to each Fibre Channel port.

WORM. See *write-once read-many*.

write-once read many (WORM). Any type of storage medium to which data can be written only a single time, but can be read from any number of times. After the data is recorded, it cannot be altered.

WWN. See *worldwide name*.

zoning. (1) In Fibre Channel environments, the grouping of multiple ports to form a virtual, private, storage network. Ports that are members of a zone can communicate with each other, but are isolated from ports in other zones. (2) A function that allows segmentation of nodes by address, name, or physical port and is provided by fabric switches or hubs.

Index

A

about this book xi
ac power cords, external 19, 34
ac power distribution unit 13
 9188/7188 16
 MAP 20
 power-off procedure 24
 power-on procedure 23
 removal 24
 replacement 25
 testing 20
 Type 6 13
attachment
 of front door 9
 of mounting plate 9
 of stabilizers 3
 to concrete floor 4, 6
audience xi

B

battery return ix
blank fillers 31
book, about this xi
brace, earthquake 30

C

checking power source 10
comments, how to send xiii
compliance statement
 European community 44
 Germany 45
concrete floor rack attachment 4, 6
connection
 of drawer and device cables 11
cords, power 19, 34
covers 29

D

device cable connection 11
disposal ix
distribution of power 13
door, removal and replacement 25
drawer connection 11
dust plugs ix

E

earthquake brace 30
edition notice ii
electrical safety 23
electronic emission
 statement 44
environmental
 notices ix
 statements ix
extent of warranty 40

external ac power cords 19, 34

F

FCC
 emission limits 44
 rules 44
 statement 44
Federal Communications Commission
 (FCC) statement 44
fire suppression xiii
front door attachment 9

G

Germany compliance statement 45
glossary 47

H

hardware service and support xii
hardware warranty 39
high voltage (ac) 19

I

IBM, warranty for machines 39
Industry Canada compliance
 statement 44
information, parts 29
inspection, safety vii
installation procedures 1
interference, radios and televisions 44

J

Japanese Voluntary Control Council for
 Interference (VCCI) class 1
 statement 46

K

Korean Government Ministry of
 Communication (MOC) statement 46

L

laser safety ix
LED 20, 27
leveling feet 34
leveling the rack 3
liability, limit of 41
light emitting diode (LED) 20, 27
limitation of liability 41
limited warranty statement (SOLW) 39

M

maintenance analysis procedures
 (MAP) 20
MAP 20
mounting plate attachment 9

N

notices 43
 environmental vii
 safety vii, 1, 3, 20, 23
 safety translation vii

O

optical ports, restrictions ix

P

parts
 blank fillers 31
 covers 29
 earthquake brace 30
 leveling feet 34
 power cords 34
 power distribution unit (PDU) 32
 stabilizers 33
parts information 29
position of the rack 2
power
 distribution of 13
power cords
 external 19, 34
power distribution unit (PDU) 13
 9188/7188 16
 parts 32
 power-off procedure 24
 power-on procedure 23
 removing 24
 replacing 25
 testing 20
 Type 6 13
power source check 10
power-off procedure 24
power-on procedure 11, 23
product specifications 29, 36
production status 39

R

rack
 leveling 3
 position 2
 power-off procedure 24
 power-on procedure 23
 relocation 26
 removal and replacement 24
 service 23
radio interference 44

range of operating temperatures ix
recycling ix
relocation of racks 26
removal and replacement
 of the doors 25
 of the PDU 24
restrictions
 maximum number of drawers per pair
 of PDUs 11, 14, 16
 of the machine ix
 of the optical ports ix
 power cord 11, 14, 16
 usage ix
warranty (*continued*)
 service
 IBM machines 40
 phone number 40
 statement, limited 39
 web sites, related xii
 who should use this book xi

S

safety
 electrical 23
 inspection procedure vii
 laser vii, ix
 notice translations vii
 notices vii, 1, 3, 10, 11, 20, 23
service, warranty 40
servicing the rack 23
software service and support xii
SOLW (limited warranty statement) 39
specifications, product 36
stabilizer attachment 3
stabilizers 33
statement
 electronic emission 44
 European community compliance 44
 Federal Communications
 Commission 44
 German only compliance
 statement 45
 Industry Canada compliance 44
 Japanese Voluntary Control Council
 for Interference (VCCI) class 1 46
 Korean Government Ministry of
 Communication (MOC) 46
 of limited warranty 39
 Taiwan class A compliance 46
status, production 39
system power on 11

T

Taiwan class A compliance statement 46
temperature range, operating ix
testing procedure, PDU 20
trademarks 43

U

unauthorized changes or
 modifications 44

W

warranty
 extent of 40
 for IBM machines 39
 hardware 39
 limited 39

Readers' comments—we would like to hear from you

IBM Storage Solution Rack
2101 Model 200
Installation and Service Guide

Publication No. SY27-7622-01

Overall, how satisfied are you with the information in this book?

	Very Satisfied	Satisfied	Neutral	Dissatisfied	Very Dissatisfied
Overall satisfaction	<input type="checkbox"/>	<input type="checkbox"/>	<input type="checkbox"/>	<input type="checkbox"/>	<input type="checkbox"/>

How satisfied are you that the information in this book is:

	Very Satisfied	Satisfied	Neutral	Dissatisfied	Very Dissatisfied
Accurate	<input type="checkbox"/>	<input type="checkbox"/>	<input type="checkbox"/>	<input type="checkbox"/>	<input type="checkbox"/>
Complete	<input type="checkbox"/>	<input type="checkbox"/>	<input type="checkbox"/>	<input type="checkbox"/>	<input type="checkbox"/>
Easy to find	<input type="checkbox"/>	<input type="checkbox"/>	<input type="checkbox"/>	<input type="checkbox"/>	<input type="checkbox"/>
Easy to understand	<input type="checkbox"/>	<input type="checkbox"/>	<input type="checkbox"/>	<input type="checkbox"/>	<input type="checkbox"/>
Well organized	<input type="checkbox"/>	<input type="checkbox"/>	<input type="checkbox"/>	<input type="checkbox"/>	<input type="checkbox"/>
Applicable to your tasks	<input type="checkbox"/>	<input type="checkbox"/>	<input type="checkbox"/>	<input type="checkbox"/>	<input type="checkbox"/>

Please tell us how we can improve this book:

Thank you for your responses. May we contact you? Yes No

When you send comments to IBM, you grant IBM a nonexclusive right to use or distribute your comments in any way it believes appropriate without incurring any obligation to you.

Name

Address

Company or Organization

Phone No.



Fold and Tape

Please do not staple

Fold and Tape



NO POSTAGE
NECESSARY
IF MAILED IN THE
UNITED STATES

BUSINESS REPLY MAIL

FIRST-CLASS MAIL PERMIT NO. 40 ARMONK, NEW YORK

POSTAGE WILL BE PAID BY ADDRESSEE

International Business Machines Corporation
RCF Processing Department
G26/050
5600 Cottle Road
San Jose, CA 95193-0001



Fold and Tape

Please do not staple

Fold and Tape



Part Number: 22R4077

Printed in USA

SY27-7622-01



(1P) P/N: 22R4077

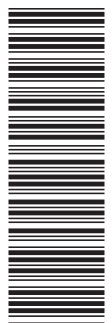

Spine information:



IBM Storage Solution Rack

Installation and Service Guide, 2101 Model 200